

The product using material and processing must conform to the "WI-PZ-001"HSF technical standard control requirements

RoHS

Circuit 1

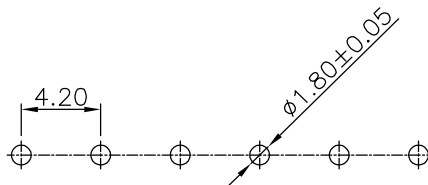
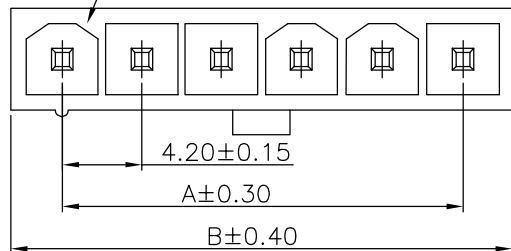

RECOMMENDED PCB LAYOUT
(GENERAL TOLERANCE:±0.05)

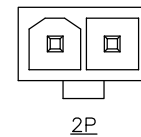

2P

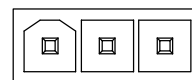

3P

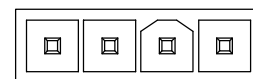

4P

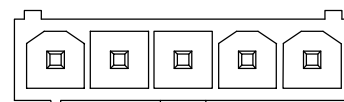

5P

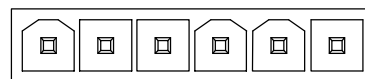

6P

- NOTE:
- MATERIAL SPECIFICATION:
 - HOUSING: PA66
 - CONTACTS: BRASS
 - PLATING SPECIFICATION:
 - CONTACTS: TIN/GOLD FLASH PLATED OVER ALL.
 - ELECTRICAL PERFORMANCE:
 - CURRENT RATING: 9A
 - CONTACT RESISTANCE: 10 mΩ MAX
 - INSULATION RESISTANCE: 1000MΩ Min
 - DIELECTRIC WITHSTANDING : 1500V
 - ENVIRONMENTAL PERFORMANCE:
 - OPERATING TEMPERATURE: -25°C~+85°C.
 - PACKAGE SPEC: PE BAG
 - P/N:

SERIES NO: C4201 W 0 1-1 XX 1 X X X
 CONNECTOR: W-WAFER
 ANGLE: 0-180°
 TYPE: 1-TYPE 1
 ROW NO: 1-SINGLE ROW
 PIN Q' PY: 02~06

HOUSING:
 0-UL94V-0
 2-UL94V-2

COLOR:
 A-BLACK
 S-NATURE

PLATING:
 C-BRIGHT TIN

TERMINPOINT:
 1-DIP

Circuit	Dimensions (mm)	
	A	B
02	4.20	9.60
03	8.40	13.80
04	12.60	18.00
05	16.80	22.20
06	21.00	26.40

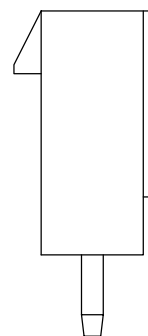
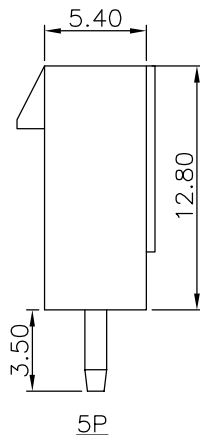
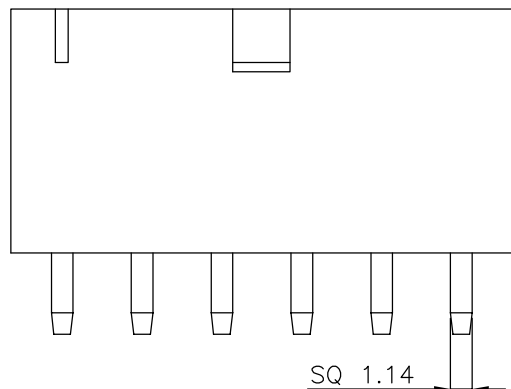

2P~4P、6P

REV.	REVISION RECORD	DATE	GENERAL TOLERANCES		SCALE:	NAME	DATE	PART.NO:	DWG.NO:
A0	NEW RELEASE	21.11.17	 LINEAR 0.0±0.35 UNIT:mm SIZE: A4	 ANGLES X'REF±6° X'±3° X'X' ±2°	1:1	Wang_jr	23.09.08	C4201W01-1XX1XXX	ENDE05
A1	PART NUMBER RENEWAL	23.09.08			0.00±0.25	0.000±0.10	APPROVED	Han_Gao	23.09.08
					DESIGNER	LX_HOU	23.09.08		SHEET: 1/2

万连科技
WanLian Technology Co., Ltd

The product using material and processing must conform to the "WI-PZ-001"HSF technical standard control requirements

RoHS

Circuit	PCS/bag	PCS/Carion
2P	1000	8000
3P	1000	8000
4P	1000	5000
5P	1000	5000
6P	500	2000

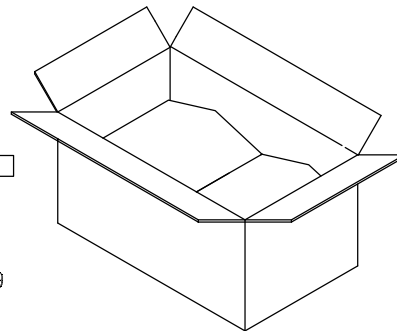
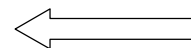
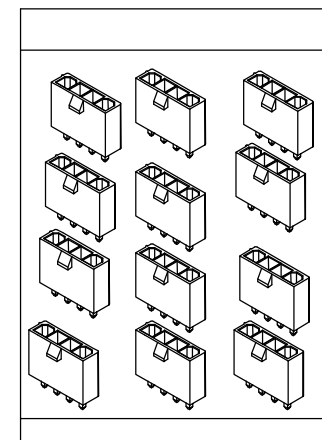
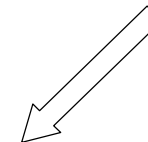
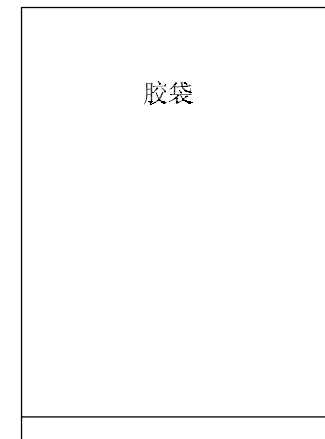
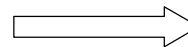
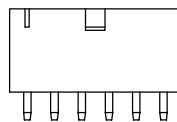

Material:K=K
MEAS:42*27*19

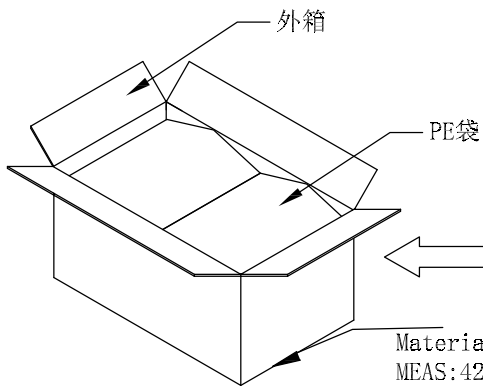

注意事项:

1. 袋装产品封口前需放1-2包干燥剂于内;
2. 内外包装均需有数量标签, 尾数包装需用不影响品质之物品填充并注明尾数。
3. 产品不可少数、多数
4. 不同PIN位包装时须分开放置, 不可装入同一外箱中。

REV.	REVISION RECORD	DATE		GENERAL TOLERANCES		SCALE: 1:1	NAME	DATE	PART.NO:	DWG.NO:	
A0	NEW RELEASE	21.11.17		LINEAR	ANGLES	APPROVED	Wang_jr	23.09.08	C4201W01-1XX1XXX	ENDE05	
A1	PART NUMBER RENEWAL	23.09.08	UNIT:mm	0.00±0.25	X'±3'	DESIGNER	Han_Gao	23.09.08	TITLE:		REV: A1 SHEET: 2/2
			SIZE: A4	0.000±0.10	X'X' ±2'	DRAWN	LX_HOU	23.09.08	Pitch 4.2mm 单排 180° DIP Wafer		

WanLian Technology Co., Ltd