

The product using material and processing must conform to the "WI-PZ-001"HSF technical standard control requirements

RoHS

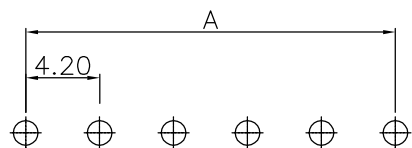

RECOMMENDED PCB LAYOUT  
(GENERAL TOLERANCE: ±0.05)

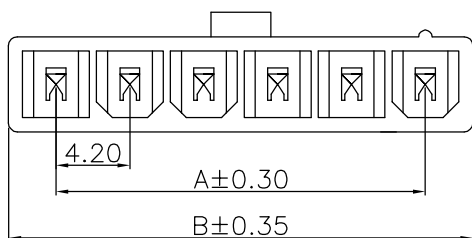
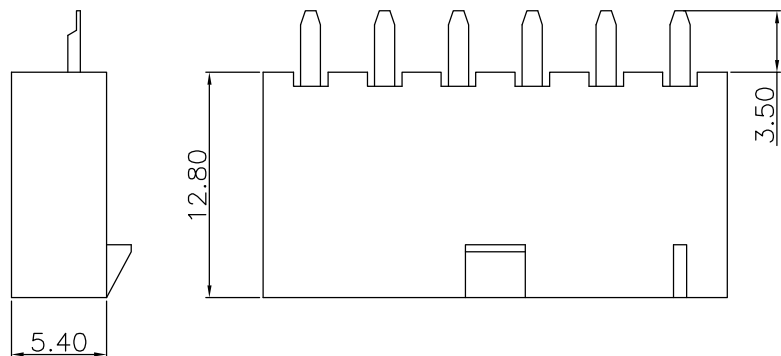
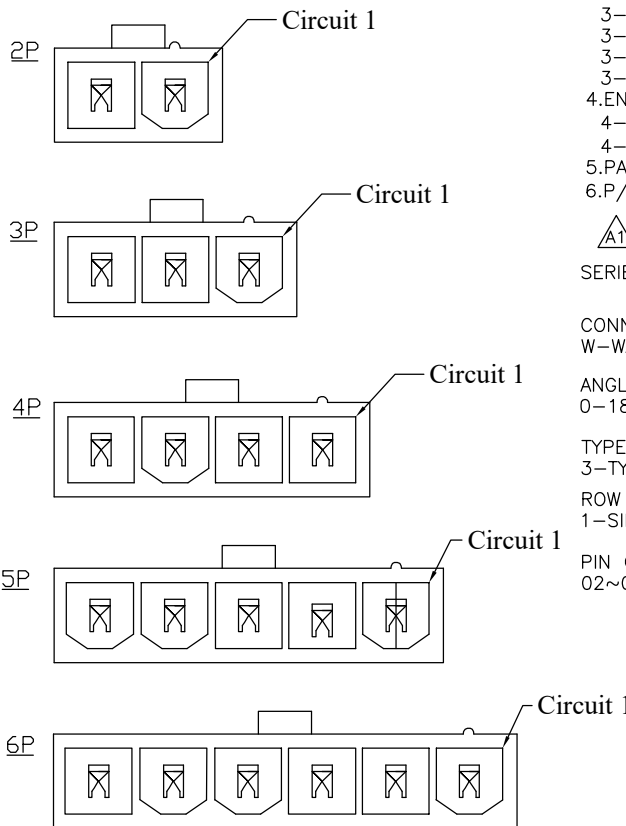

NOTE:  
 1.MATERIAL SPECIFICATION:  
 1-1.HOUSING: PA66/LCP  
 1-2.CONTACTS: BRASS  
 2.PLATING SPECIFICATION:  
 2-1.CONTACTS:  
 TIN/GOLD FLASH PLATED OVER ALL.  
 3.ELECTRICAL PERFORMANCE:  
 3-1.CURRENT RATING: 9A AC/DC  
 3-2.CONTACT RESISTANCE: 10 mΩ MAX  
 3-3.INSULATION RESISTANCE: 1000MΩ Min  
 3-4.DIELECTRIC WITHSTANDING : 1500V  
 4.ENVIRONMENTAL PERFORMANCE:  
 4-1.OPERATING TEMPERATURE: LCP/-40°C~+105°C.  
 4-2.OPERATING TEMPERATURE: PA66/-25°C~+85°C.  
 5.PACKAGE SPEC: PE BAG  
 6.P/N:  
 A1 C4201 W 0 3-1 XX 1 X X X  
 SERIES NO: HOUSING  
 0-PA66,UL94V-0  
 2-PA66,UL94V-2  
 3-LCP,UL94V-0(RoHS+HF)  
 CONNECTOR: COLOR:  
 W-WAFER S-NATURE  
 ANGLE: PLATING:  
 0-180° C-BRIGHT TIN  
 TYPE: 3-TYPE 3  
 ROW NO: 1-SINGLE ROW  
 PIN Q'PY: TERMPOINT:  
 02~06 1-DIP

Ordering Information & Dimensions

Circuit	Dimensions(mm)	
	A	B
02	4.20	9.60
03	8.40	13.80
04	12.60	18.00
05	16.80	22.20
06	21.00	26.40

REV.	REVISION RECORD	DATE	UNIT:mm	GENERAL TOLERANCES		SCALE: 1:1	NAME	DATE	PART.NO:	DWG.NO:	WanLian Technology Co., Ltd
A0	NEW RELEASE	22.07.07		LINEAR	ANGLES	APPROVED	Wang_jr	23.09.11	C4201W03-1XX1XXX	ENDE05	
A1	PART NUMBER RENEWAL	23.09.11	0.00±0.25	X'±3'	DESIGNER	Han_Gao	23.09.11	TITLE:	Pitch 4.2mm 单排 180° DIP Wafer 空心针	REV: A1	SHEET: 1/2
			SIZE: A4	0.000±0.10	X'X' ±2'	DRAWN	LanXuan_Hou	23.09.11			



The product using material and processing must conform to the "WI-PZ-001"HSF technical standard control requirements

RoHS

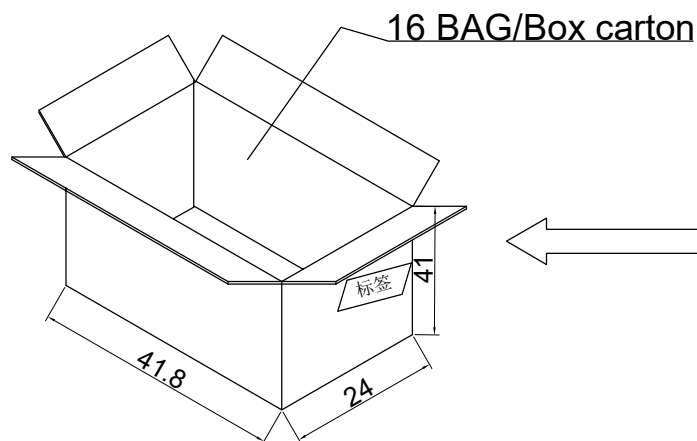
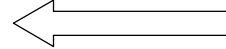
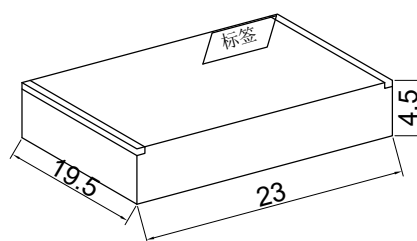
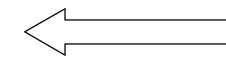
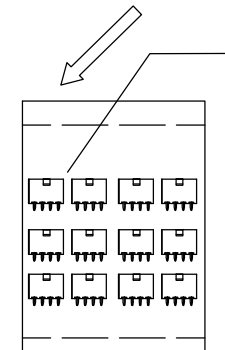
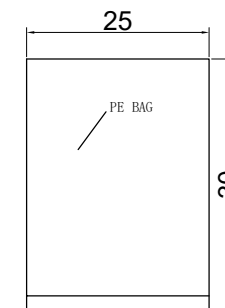
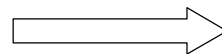
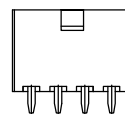

Circuit	PCS/bag	16bag/Carton
2P	500	9000
3P	500	9000
4P	250	4000
5P	250	4000
6P	250	4000

注意事项:

1. 产品不可少数、多数，方向须一致，每袋1-2pcs干燥剂。
2. 内外包装均需有数量标签，尾数包装需用不影响品质之物品填充并注明尾数。
3. 包装数量按左侧表格。
4. 小盒子、外箱均需要贴标签。

REV.	REVISION RECORD	DATE		GENERAL TOLERANCES		SCALE: 1:1	NAME	DATE	PART.NO:	DWG.NO:	
A0	NEW RELEASE	22.07.07		LINEAR	ANGLES	APPROVED	Wang_jr	23.09.11	C4201W03-1XX1XXX	ENDE05	
A1	PART NUMBER RENEWAL	23.09.11	UNIT:mm	0.00±0.25	X'±3'	DESIGNER	Han_Gao	23.09.11	TITLE:		REV: A1      SHEET: 2/2
			SIZE: A4	0.000±0.10	X'X' ±2'	DRAWN	LanXuan_Hou	23.09.11	Pitch 4.2mm 单排 180° DIP Wafer 空心针		

WanLian Technology Co., Ltd