

The product using material and processing must conform to the "WI-PZ-001"HSF technical standard control requirements

RoHS

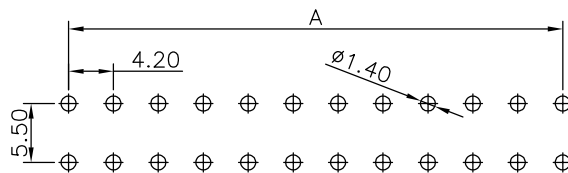

RECOMMENDED PCB LAYOUT
(GENERAL TOLERANCE:±0.05)

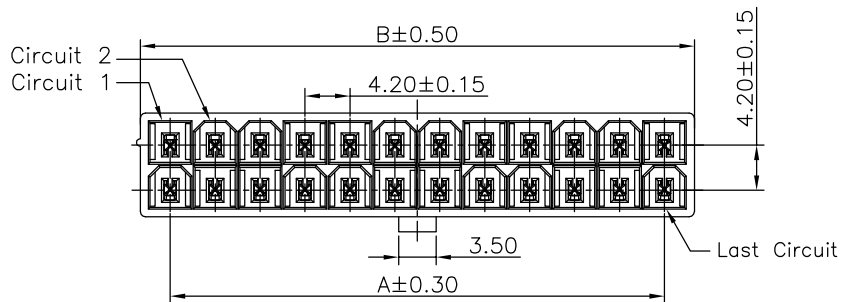
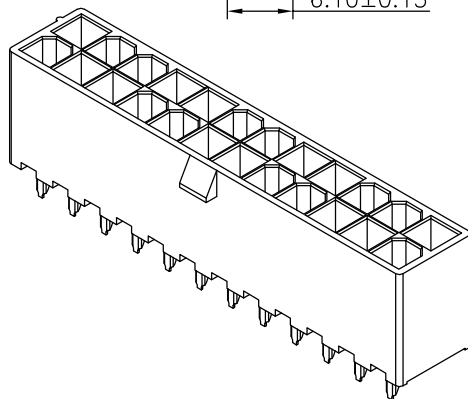
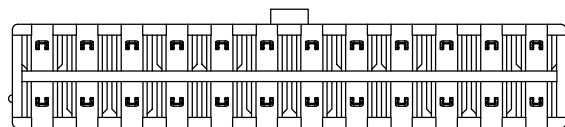
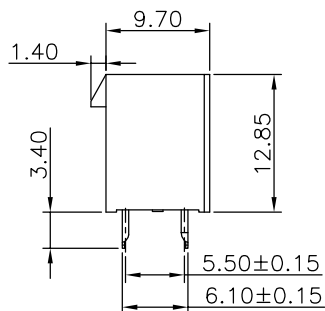
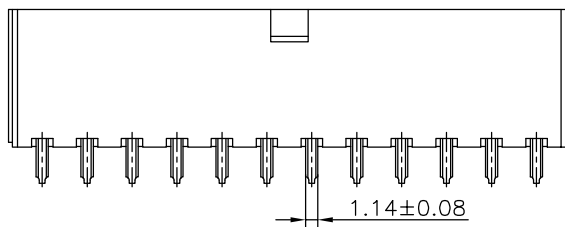

NOTE:

- 1.MATERIAL SPECIFICATION:
 - 1-1.HOUSING: PA66/ LCP
 - 1-2.CONTACTS: BRASS
- 2.PLATING SPECIFICATION:
 - 2-1.CONTACTS: TIN/GOLD FLASH PLATED OVER ALL.
- 3.ELECTRICAL PERFORMANCE:
 - 3-1.CURRENT RATING: 9A
 - 3-2.CONTACT RESISTANCE: 10 mΩ MAX
 - 3-3.INSULATION RESISTANCE: 1000MΩ Min
 - 3-4.DIELECTRIC WITHSTANDING : 1500V
- 4.ENVIRONMENTAL PERFORMANCE:
 - 4-1.OPERATING TEMPERATURE: -25°C~+85°C/PA66
 - 4-2.OPERATING TEMPERATURE: -40°C~+105°C/LCP
- 5.PACKAGE SPEC: TRAY+PE BAG
- 6.P/N:



C4201 W 0 3-2 XX 1 X X X

SERIES NO: _____

CONNECTOR: _____

W-WAFER

ANGLE: _____

0-180°

TYPE: _____

3-TYPE 3

ROW NO: _____

2-DOUBLE ROW

PIN Q'PY: _____

02~24

HOUSING

0-PA66,UL94V-0

2-PA66,UL94V-2

3-LCP(RoHS+HF)

COLOR:

A-BLACK

S-NATURE

PLATING:

C-BRIGHE TIN

TERMPIPOINT:

1-DIP

Ordering Information & Dimensions

Circuit	Dimensions(mm)		Circuit	Dimensions(mm)	
	A	B		A	B
2*01	---	5.60	2*07	25.20	30.80
2*02	4.20	9.80	2*08	29.40	35.00
2*03	8.40	14.00	2*09	33.60	39.20
2*04	12.60	18.20	2*10	37.80	43.40
2*05	16.80	22.40	2*11	42.00	47.60
2*06	21.00	26.60	2*12	46.20	51.80

REV.	REVISION RECORD	DATE	UNIT:mm	GENERAL TOLERANCES		SCALE:	NAME	DATE	PART.NO:	DWG.NO:	REV: A1	SHEET: 1/3
A0	NEW RELEASE	21.11.17		LINEAR	ANGLES	1:1						
A1	PART NUMBER RENEWAL	23.09.08	0.00±0.25	X'±3'	APPROVED	Wang_jr	23.09.08	C4201W03-2XX1XXX	ENDE05	<p>WanLian Technology Co., Ltd</p>		
			0.00±0.10	X'X' ±2'	DESIGNER	Han_Gao	23.09.08	TITLE:				
			SIZE: A4		DRAWN	Zijun_Huang	23.09.08	Pitch 4.2mm 双排 180° DIP Wafer 空心针				

The product using material and processing must conform to the "WI-PZ-001"HSF technical standard control requirements

RoHS

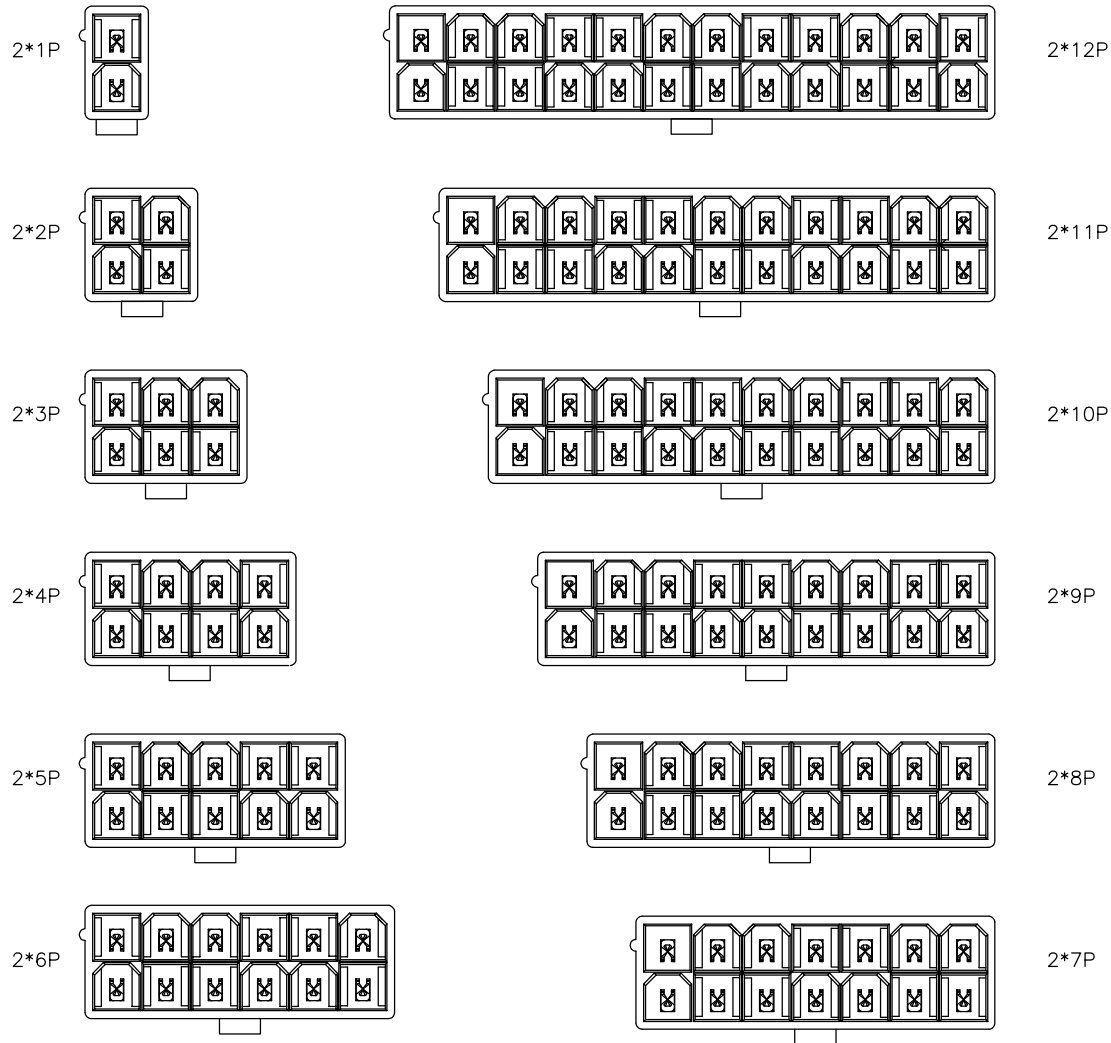

REV.	REVISION RECORD	DATE		GENERAL TOLERANCES		SCALE: 1:1	NAME	DATE	PART.NO:	DWG.NO:	 WanLian Technology Co., Ltd	
A0	NEW RELEASE	21.11.17		LINEAR	ANGLES	APPROVED	Wang_jr	23.09.08	C4201W03-2XX1XXX	ENDE05		
A1	PART NUMBER RENEWAL	23.09.08		0.0±0.35	X'REF±6°	DESIGNER	Han_Gao	23.09.08	TITLE: Pitch 4.2mm 双排 180° DIP Wafer 空心针	REV: A1		SHEET: 2/3
				UNIT:mm	X'±3°	DRAWN	Zijun_Huang	23.09.08				
			SIZE: A4	0.000±0.10	X'X' ±2°							

The product using material and processing must conform to the "WI-PZ-001"HSF technical standard control requirements

RoHS

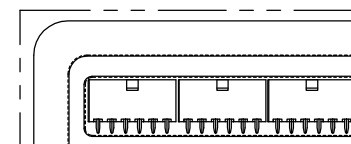
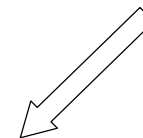
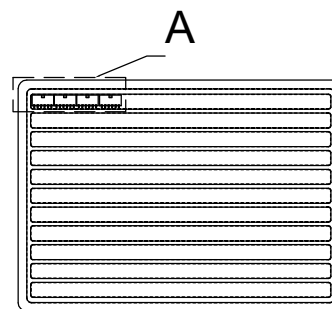
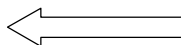
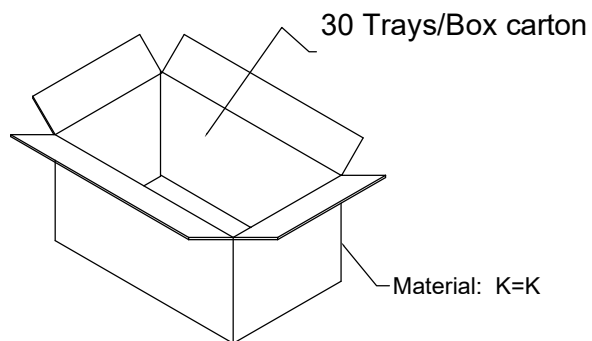
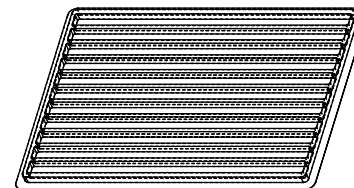
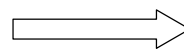
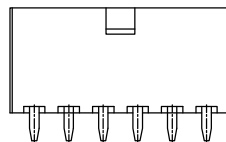
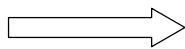
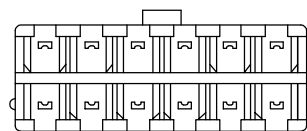

A
4:1

Circuits	PCS/Tray	30Trays/Carton	Circuits	PCS/Tray	30Trays/Carton
2*1P 无柱	1000/袋		2*7P 无柱	121	3630
2*2P 无柱	374	11220	2*8P 无柱	99	2970
2*3P 无柱	264	7920	2*9P 无柱	88	2640
2*4P 无柱	198	5940	2*10P 无柱	88	2640
2*5P 无柱	165	4950	2*11P 无柱	77	2310
2*6P 无柱	132	3960	2*12P 无柱	66	1980

注意事项:

1. 盒装产品四周需用胶纸固定（一盘一盖）；袋装产品封口前需放1-2包干燥剂于内；卷装产品前后需留10-20PCS产品空格。
2. 产品不可少数、多数，方向须一致。
3. 内外包装均需有数量标签，尾数包装需用不影响品质之物品填充并注明尾数。
4. 所有PIN位6盘/捆(用PE膜缠绕)，5捆/箱
5. 纸箱规格：39.5X28.5X39.5CM

REV.	REVISION RECORD	DATE	UNIT:mm	GENERAL TOLERANCES		SCALE: 1:1	NAME	DATE	PART.NO:	DWG.NO:	 WanLian Technology Co., Ltd
A0	NEW RELEASE	21.11.17		LINEAR	ANGLES	APPROVED	Wang_jr	23.09.08	C4201W03-2XX1XXX	ENDE05	
A1	PART NUMBER RENEWAL	23.09.08	0.00±0.25	X'±3'	DESIGNER	Han_Gao	23.09.08	TITLE:		REV: A1	SHEET: 3/3
			SIZE: A4	0.000±0.10	X'X' ±2'	DRAWN	Zijun_Huang	23.09.08	包装图		