

The product using material and processing must conform to the "WI-PZ-001"HSF technical standard control requirements

RoHS

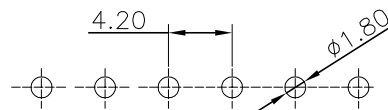

P.C.B LAYOUT

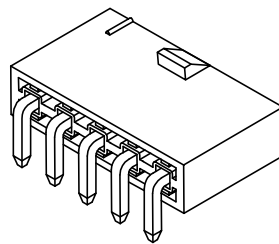
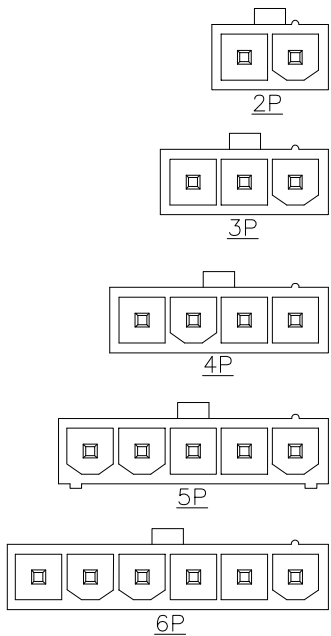
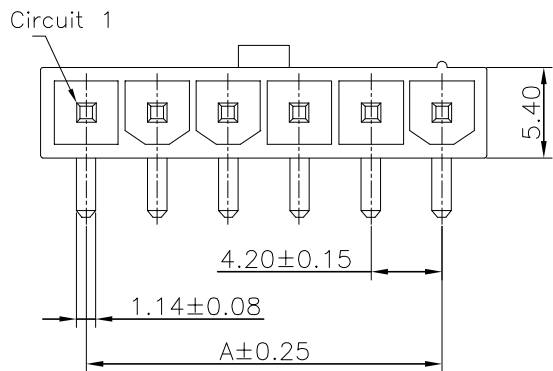
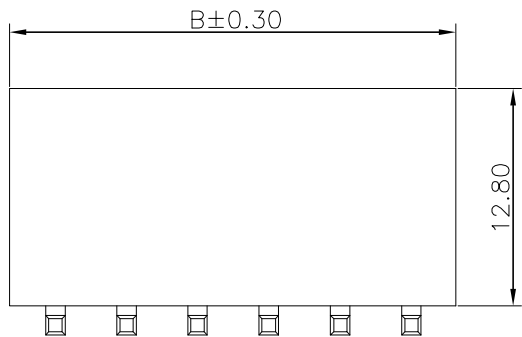

2~4PIN&6PIN

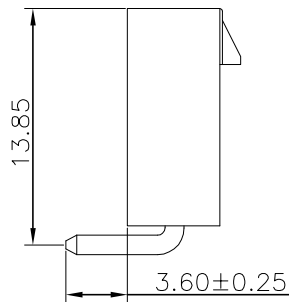

5PIN:有筋条

- NOTE:
- MATERIAL SPECIFICATION:
 - HOUSING: PA66
 - CONTACTS: BRASS
 - PLATING SPECIFICATION:
 - CONTACTS: TIN/GOLD FLASH PLATED OVER ALL.
 - ELECTRICAL PERFORMANCE:
 - CURRENT RATING: 9A
 - CONTACT RESISTANCE: 10 mΩ MAX
 - INSULATION RESISTANCE: 1000MΩ Min
 - DIELECTRIC WITHSTANDING : 1500V
 - ENVIRONMENTAL PERFORMANCE:
 - OPERATING TEMPERATURE: -25°C~+85°C.
 - PACKAGE SPEC: REEL
 - P/N:

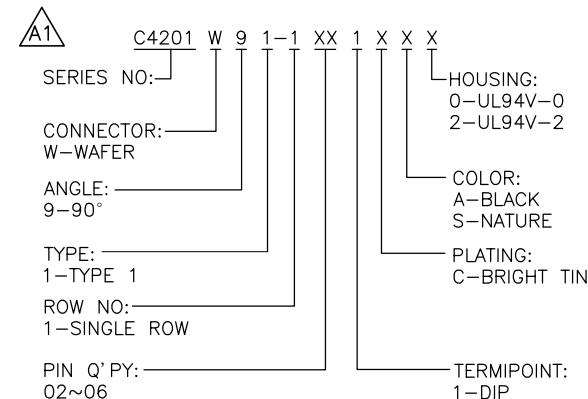

Circuit	Dimensions (mm)	
	A	B
2	4.20	9.60
3	8.40	13.80
4	12.60	18.00
5	16.80	22.20
6	21.00	26.40

REV.	REVISION RECORD	DATE	GENERAL TOLERANCES		SCALE:	NAME	DATE	PART.NO:	DWG.NO:		
A0	NEW RELEASE	21.11.17	LINEAR	ANGLES	1:1	Wang_jr	23.09.08	C4201W91-1XX1XXX	ENDE05		
A1	PART NUMBER RENEWAL	23.09.08	0.00±0.25	X'±3'	APPROVED	Han_Gao	23.09.08	TITLE:			
			0.000±0.10	X'X' ±2'	DESIGNER	Zijun_Huang	23.09.08	Pitch 4.2mm 单排 90° DIP Wafer			
			UNIT:mm		DRAWN					REV: A1	SHEET: 1/2

The product using material and processing must conform to the "WI-PZ-001" HSF technical standard control requirements

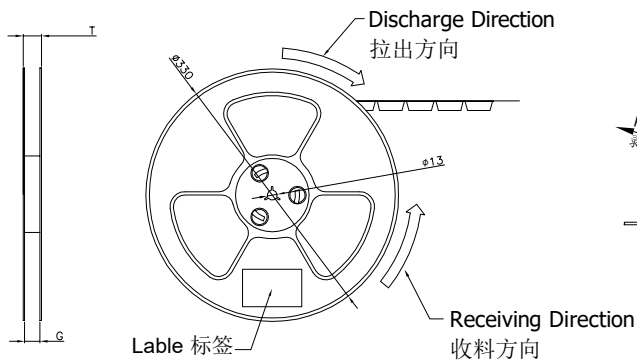
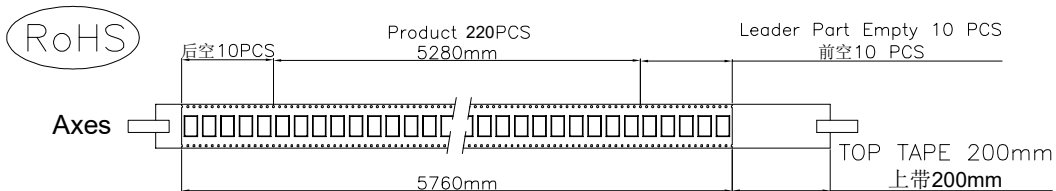

COVER TAPE PEEL STRENGTH: 20~120g
上带剥离力量: 20~120g
速度 PEEL SPEED: 300mm/minute

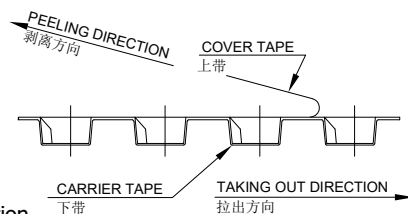

Lable 标签
Single hole: None Hole Side
单孔: 贴无链孔侧
Double hole: Elliptical Hole Side
双孔: 贴椭圆孔侧

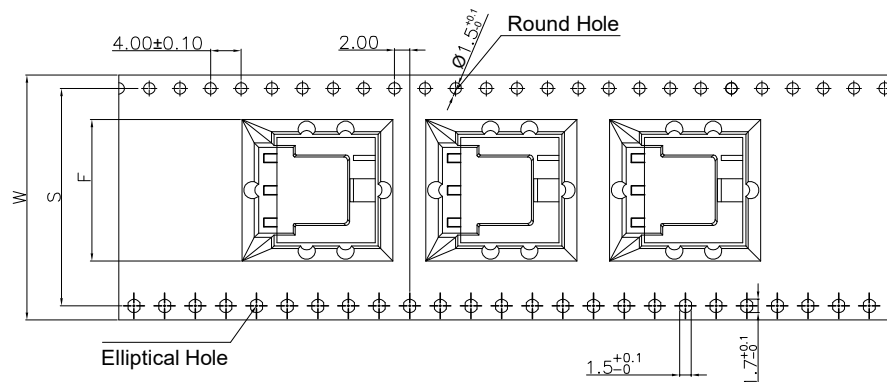
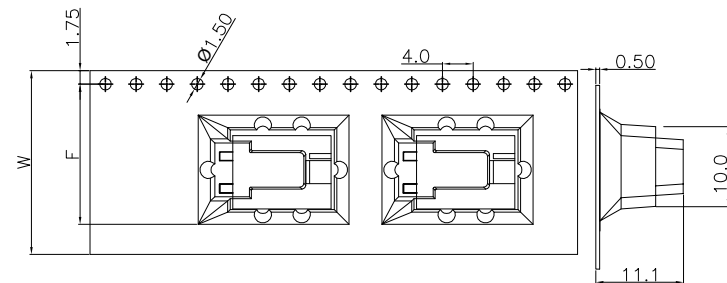
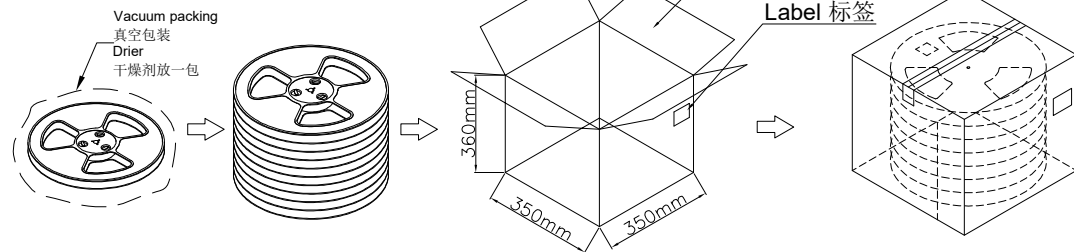

Note:

- Carrier Camber Is Within 1mm In 100mm ; 带长100mm内容许弯曲度1mm
- 10 Sprocket Hole Pitch Cumulative Tolerance±0.2MM ; 圆孔十个孔距离累计允许公差为±0.2mm
- Carrier Tape Material for PS ; 下带材质为PS材质 ; Color颜色: Black黑色
- bracer保护带: Color颜色:Black黑色;厚度0.40mm最小
- Thickness=0.50±0.05 ; 材料厚度为0.50±0.05mm
- Cover Tape上带: 冷风自粘带

Circuit	W	S	F	T	G	Cover Tape(宽) (W)	Carrier Tape(Color) (颜色)	REEL /PCS	CARTON /R	CARTON /PCS
02	24	/	11.75	28.0	25.4	21.3	黑色	220	12	2400
03	32	28.4	14.20	36.0	33.4	25.5		220	9	1980
04	44	40.4	20.20	48	44.4	37.5		220	7	1540
05										
06	56	52.4	26.20	60	56.4	49.5		220	5	1100

REV.	REVISION RECORD	DATE	GENERAL TOLERANCES		SCALE:	NAME	DATE	PART.NO:	DWG.NO:	 WanLian Technology Co., Ltd
A0	NEW RELEASE	21.11.17		LINEAR	1:1	Wang_jr	23.09.08	C4201W91-1XX1XXX	ENDE05	
A1	PART NUMBER RENEWAL	23.09.08		ANGLES						
			UNIT:mm	0.00±0.25	X'±3'	DESIGNER	Han_Gao	23.09.08	TITLE:	
			SIZE: A4	0.000±0.10	X'X' ±2'	DRAWN	Zijun_Huang	23.09.08	包装图	SHEET: 2/2