

PUSHIN轨道目录书

PUSHIN TRACK CATALOG BOOK



公司简介

COMPANY PROFILE



电子谷是连接器全品类一站式服务平台。平台拥有100万物料产品，覆盖消费类电子、新能源、汽车、智能家居、5G、医疗、航空、工业机器人等多种行业。电子谷凝聚20年连接器研发、制造、服务经验，为用户提供BOM表智能报价、专属FAE支持、来图定制等多种在线服务。致力打造连接器全品类一站式服务平台，实现连接器采购的数字化、高效化。

16万m²生产厂房

超大工业集群，厂区面积超16万+m²，内设行业先进生产设备与技术，为交期提供强有力的生产保障。



扫码VR看厂

16万+m²生产厂房

503+人研发团队

连接器全品类一站式服务平台

电子谷6S服务



专属客服 FAE支持
FAE Support

专属客服7X24小时服务
FAE工程师在线技术支持



海量库存 闪电发货
Speedy Delivery

自有仓储，海量现货备货
为产品交期提供保障



快捷报价 分秒必争
Swift Quote

智能BOM快速报价，
深度学习引擎秒配50万物料SKU



精益生产 严控品质
Stringent Quality Control

信息化、精益化的
生产流程和完整的品质管理体系



品类齐全 一站采购
One-stop shopping

原厂、国产全品类供应
连接器一站采购，降低采购成本



自有工厂 优势价格
Superior Price

自有工厂加优质供应链
价格优势就在电子谷商城



应用场景

APPLICATION SCENARIO



轨道交通行业

RAIL TRANSIT INDUSTRY

能源行业

ENERGY INDUSTRY



自动化行业

AUTOMATION INDUSTRY



机器人行业

ROBOT INDUSTRY



机械设备行业

MACHINERY INDUSTRY



舞台照明行业

STAGE LIGHTING INDUSTRY



汽车/新能源行业

AUTOMOTIVE/NEW ENERGY INDUSTRY

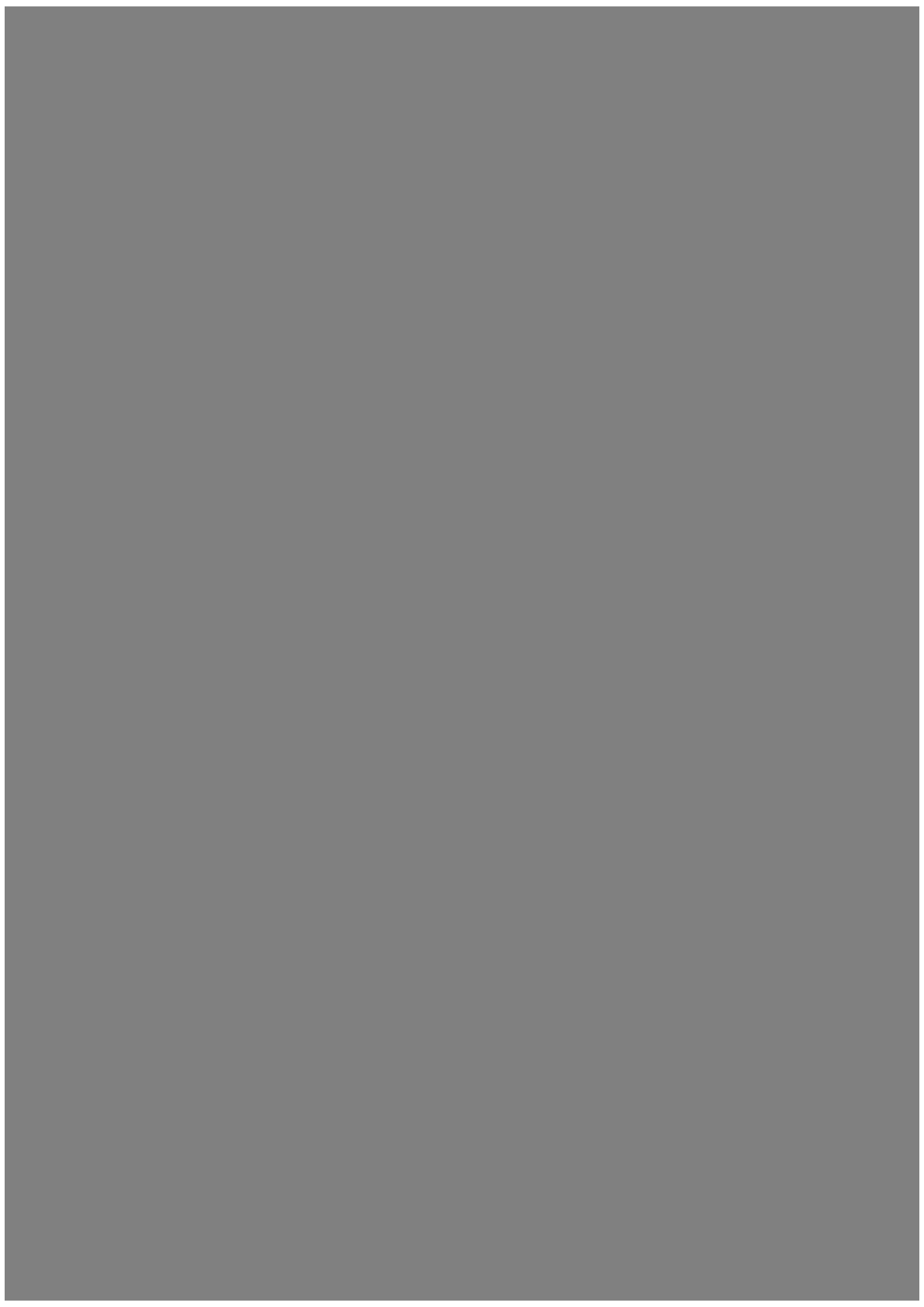

Spring-clamp & Push-in Din Rail Terminal Blocks

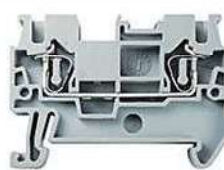

Features of Spring Clamp Terminal Blocks

DST1.5-D
1.5mm² **Page13**

UL	600V / 15A / AWG 28-14
CSA	600V / 15A / AWG 28-14
IEC	500V / 17.5A / 0.08-2.5mm ²



Features of Spring Clamp Terminal Blocks

DST1.5/3-D
1.5mm² **Page14**

UL	600V / 15A / AWG 28-14
CSA	600V / 15A / AWG 28-14
IEC	500V / 17.5A / 0.08-2.5mm ²



Features of Spring Clamp Terminal Blocks

DST1.5/4-D
1.5mm² **Page14**

UL	600V / 15A / AWG 28-14
CSA	600V / 15A / AWG 28-14
IEC	500V / 17.5A / 0.08-2.5mm ²

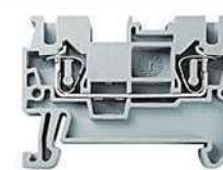

Features of Spring Clamp Terminal Blocks

DST2.5-D
2.5mm² **Page14**

UL	600V / 20A / AWG 28-12
CSA	600V / 20A / AWG 28-12
IEC	800V / 31A / 0.08-4mm ²

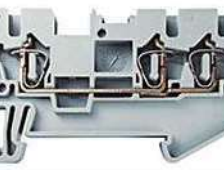

Features of Spring Clamp Terminal Blocks

DST2.5/3-D
2.5mm² **Page15**

UL	600V / 20A / AWG 28-12
CSA	600V / 20A / AWG 28-12
IEC	800V / 28A / 0.08-4mm ²



Features of Spring Clamp Terminal Blocks

DST2.5/4-D
2.5mm² **Page15**

UL	600V / 20A / AWG 28-12
CSA	600V / 20A / AWG 28-12
IEC	800V / 28A / 0.08-4mm ²

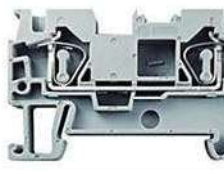

Features of Spring Clamp Terminal Blocks

DST4-D
4mm² **Page15**

UL	600V / 30A / AWG 28-10
CSA	600V / 30A / AWG 28-10
IEC	800V / 40A / 0.08-6mm ²



Features of Spring Clamp Terminal Blocks

DST4/3-D
4mm² **Page16**

UL	600V / 30A / AWG 28-10
CSA	600V / 30A / AWG 28-10
IEC	800V / 40A / 0.08-6mm ²



Features of Spring Clamp Terminal Blocks

DST4/4-D
4mm² **Page16**

UL	600V / 30A / AWG 28-10
CSA	600V / 30A / AWG 28-10
IEC	800V / 40A / 0.08-6mm ²

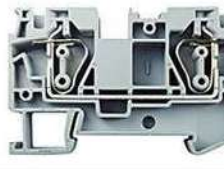

Features of Spring Clamp Terminal Blocks

DST6-D
6mm² **Page16**

UL	600V / 48A / AWG 24-8
CSA	600V / 48A / AWG 24-8
IEC	1000V / 52A / 0.2-10mm ²

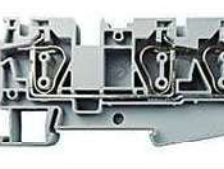

Features of Spring Clamp Terminal Blocks

DST6/3-D
6mm² **Page17**

UL	600V / 48A / AWG 24-8
CSA	600V / 48A / AWG 24-8
IEC	800V / 52A / 0.2-10mm ²



Features of Spring Clamp Terminal Blocks

DST10-D
10mm² **Page17**

UL	600V / 65A / AWG 24-6
CSA	600V / 65A / AWG 24-6
IEC	1000V / 65A / 0.2-16mm ²



Features of Spring Clamp Terminal Blocks

DST10/3-D
10mm² **Page17**

UL	600V / 60A / AWG 24-6
CSA	600V / 60A / AWG 24-6
IEC	1000V / 65A / 0.2-16mm ²



Features of Spring Clamp Terminal Blocks

DST16-D
16mm² **Page18**

UL	600V / 80A / AWG 24-4
CSA	600V / 80A / AWG 24-4
IEC	1000V / 90A / 0.2-25mm ²

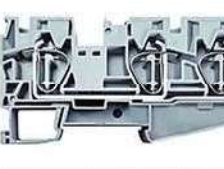

Features of Spring Clamp Terminal Blocks

DST16/3-D
16mm² **Page18**

UL	600V / 80A / AWG 24-4
CSA	600V / 80A / AWG 24-4
IEC	1000V / 90A / 0.2-25mm ²

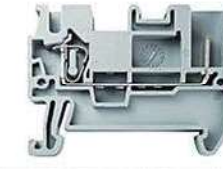

Features of Spring Clamp Terminal Blocks

DST2.5/1P-D
2.5mm² **Page18**

UL	600V / 20A / AWG 28-12
CSA	600V / 20A / AWG 28-12
IEC	500V / 24A / 0.08-4mm ²

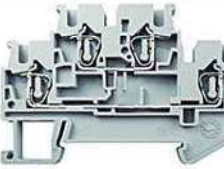

Features of Spring Clamp Terminal Blocks

DSTTB2.5-D
2.5mm² **Page19**

UL	600V / 20A / AWG 28-12
CSA	600V / 20A / AWG 28-12
IEC	500V / 26A / 0.08-4mm ²

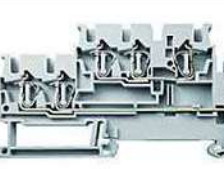

Features of Spring Clamp Terminal Blocks

DSTTB2.5/3-D
2.5mm² **Page19**

UL	300V / 20A / AWG 28-12
CSA	300V / 20A / AWG 28-12
IEC	500V / 26A / 0.08-4mm ²

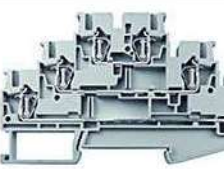

Features of Spring Clamp Terminal Blocks

DST2.5-3L-D
2.5mm² **Page19**

UL	600V / 20A / AWG 28-12
CSA	600V / 20A / AWG 28-12
IEC	500V / 26A / 0.08-4mm ²



Features of Spring Clamp Terminal Blocks

DSTTB4-D
4mm² **Page20**

UL	600V / 30A / AWG 28-10
CSA	600V / 30A / AWG 28-10
IEC	500V / 32A / 0.08-6mm ²



Features of Spring Clamp Terminal Blocks
DST2.5-MT-D
 2.5mm² **Page20**
UL 600V / 16A / AWG 28-12
CSA 600V / 16A / AWG 28-12
IEC 400V / 20A / 0.08-4mm²

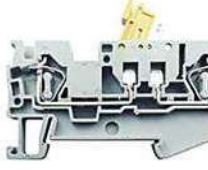

Features of Spring Clamp Terminal Blocks
DST4-MT-D
 4mm² **Page20**
UL 600V / 21A / AWG 28-10
CSA 600V / 21A / AWG 28-10
IEC 400V / 20A / 0.08-6mm²



Features of Spring Clamp Terminal Blocks
DST4-HESILED24-D
 4mm² **Page21**
UL 600V / 10A / AWG 28-10
CSA 600V / 10A / AWG 28-10
IEC 500V / 6.3A / 0.08-6mm²



Features of Spring Clamp Terminal Blocks
DST4-HESILED60-D
 4mm² **Page21**
UL 600V / 10A / AWG 28-10
CSA 600V / 10A / AWG 28-10
IEC 500V / 6.3A / 0.08-6mm²



Features of Spring Clamp Terminal Blocks
DST4-HESILED250-D
 4mm² **Page21**
UL 600V / 10A / AWG 28-10
CSA 600V / 10A / AWG 28-10
IEC 500V / 6.3A / 0.08-6mm²



Features of Spring Clamp Terminal Blocks
DST4-HEDI-D
 4mm² **Page22**
UL 600V / 10A / AWG 28-10
CSA 600V / 10A / AWG 28-10
IEC 500V / 20A / 0.08-6mm²



Features of Spring Clamp Terminal Blocks
DST4-HESI-D
 4mm² **Page22**
UL 600V / 10A / AWG 28-10
CSA 600V / 10A / AWG 28-10
IEC 500V / 6.3A / 0.08-6mm²

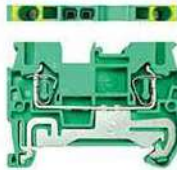

Features of Spring Clamp Ground Terminal Blocks
DST1.5-PE-D
 1.5mm² **Page23**
UL AWG 28-14
CSA AWG 28-14
IEC 0.08-2.5mm²

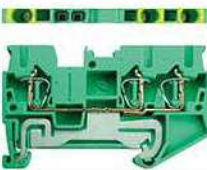

Features of Spring Clamp Ground Terminal Blocks
DST1.5/3-PE-D
 1.5mm² **Page24**
UL AWG 28-14
CSA AWG 28-14
IEC 0.08-2.5mm²

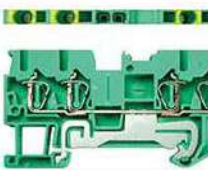

Features of Spring Clamp Ground Terminal Blocks
DST1.5/4-PE-D
 1.5mm² **Page24**
UL AWG 28-14
CSA AWG 28-14
IEC 0.08-2.5mm²



Features of Spring Clamp Ground Terminal Blocks
DST2.5-PE-D
 2.5mm² **Page24**
UL AWG 28-12
CSA AWG 28-12
IEC 0.08-4mm²



Features of Spring Clamp Ground Terminal Blocks
DST2.5/3-PE-D
 2.5mm² **Page25**
UL AWG 28-12
CSA AWG 28-12
IEC 0.08-4mm²



Features of Spring Clamp Ground Terminal Blocks
DST2.5/4-PE-D
 2.5mm² **Page25**
UL AWG 28-12
CSA AWG 28-12
IEC 0.08-4mm²

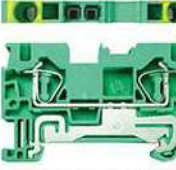

Features of Spring Clamp Ground Terminal Blocks
DST4-PE-D
 4mm² **Page25**
UL AWG 28-10
CSA AWG 28-10
IEC 0.08-6mm²

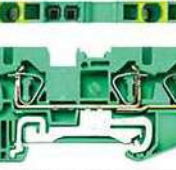

Features of Spring Clamp Ground Terminal Blocks
DST4/3-PE-D
 4mm² **Page26**
UL AWG 28-10
CSA AWG 28-10
IEC 0.08-6mm²

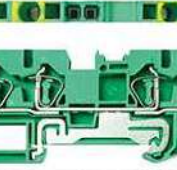

Features of Spring Clamp Ground Terminal Blocks
DST4/4-PE-D
 4mm² **Page26**
UL AWG 28-10
CSA AWG 28-10
IEC 0.08-6mm²



Features of Spring Clamp Ground Terminal Blocks
DST6-PE-D
 6mm² **Page26**
UL AWG 24-8
CSA AWG 24-8
IEC 0.2-10mm²

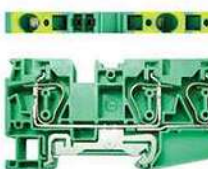

Features of Spring Clamp Ground Terminal Blocks
DST6/3-PE-D
 6mm² **Page27**
UL AWG 24-8
CSA AWG 24-8
IEC 0.2-10mm²



Features of Spring Clamp Ground Terminal Blocks
DST10-PE-D
 10mm² **Page27**
UL AWG 24-6
CSA AWG 24-6
IEC 0.2-16mm²



Features of Spring Clamp Ground Terminal Blocks
DST10/3-PE-D
 10mm² **Page27**
UL AWG 24-6
CSA AWG 24-6
IEC 0.2-16mm²

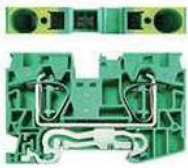

Features of Spring Clamp Ground Terminal Blocks
DST16-PE-D
 16mm² **Page28**
UL AWG 24-4
CSA AWG 24-4
IEC 0.2-25mm²

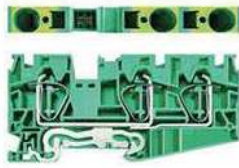

Features of Spring Clamp Ground Terminal Blocks
DST16/3-PE-D
 16mm² **Page28**
UL AWG 24-4
CSA AWG 24-4
IEC 0.2-25mm²



Features of Spring Clamp Ground Terminal Blocks
DST2.5/1P-PE-D
 2.5mm² **Page28**
UL AWG 28-12
CSA AWG 28-12
IEC 0.08-4mm²



Features of Spring Clamp Ground Terminal Blocks
DSTTB2.5-PE-D
 2.5mm² **Page29**
UL AWG 28-12
CSA AWG 28-12
IEC 0.08-4mm²



Features of Spring Clamp Terminal Blocks
DPT1.5 PUSH IN DESIGN
 1.5mm² **Page30**
UL 600V / 15A / AWG 26-14
CSA 600V / 15A / AWG 26-14
IEC 500V / 17.5A / 0.14-1.5mm²

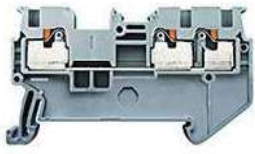

Features of Spring Clamp Terminal Blocks
DPT1.5/3 PUSH IN DESIGN
 1.5mm² **Page31**
UL 600V / 15A / AWG 26-14
CSA 600V / 15A / AWG 26-14
IEC 500V / 17.5A / 0.14-1.5mm²



Features of Spring Clamp Terminal Blocks
DPT1.5/4 PUSH IN DESIGN
 1.5mm² **Page31**
UL 600V / 15A / AWG 26-14
CSA 600V / 15A / AWG 26-14
IEC 500V / 17.5A / 0.14-1.5mm²



Features of Spring Clamp Terminal Blocks
DPT2.5 PUSH IN DESIGN
 2.5mm² **Page31**
UL 600V / 20A / AWG 26-12
CSA 600V / 20A / AWG 26-12
IEC 800V / 30A / 0.14-4mm²

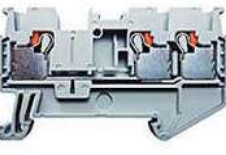

Features of Spring Clamp Terminal Blocks
DPT2.5/3 PUSH IN DESIGN
 2.5mm² **Page32**
UL 600V / 20A / AWG 26-12
CSA 600V / 20A / AWG 26-12
IEC 800V / 30A / 0.14-4mm²

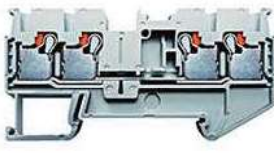

Features of Spring Clamp Terminal Blocks
DPT2.5/4 PUSH IN DESIGN
 2.5mm² **Page32**
UL 600V / 20A / AWG 26-12
CSA 600V / 20A / AWG 26-12
IEC 800V / 30A / 0.14-4mm²



Features of Spring Clamp Terminal Blocks
DPT4 PUSH IN DESIGN
 4mm² **Page32**
UL 600V / 30A / AWG 24-10
CSA 600V / 30A / AWG 24-10
IEC 800V / 38A / 0.2-6mm²

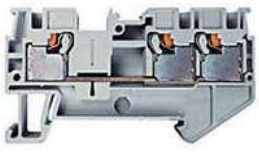

Features of Spring Clamp Terminal Blocks
DPT4/3 PUSH IN DESIGN
 4mm² **Page33**
UL 600V / 30A / AWG 24-10
CSA 600V / 30A / AWG 24-10
IEC 800V / 38A / 0.2-6mm²

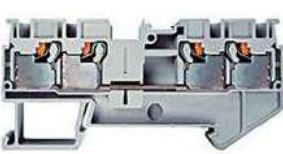

Features of Spring Clamp Terminal Blocks
DPT4/4 PUSH IN DESIGN
 4mm² **Page33**
UL 600V / 30A / AWG 24-10
CSA 600V / 30A / AWG 24-10
IEC 800V / 38A / 0.2-6mm²



Features of Spring Clamp Terminal Blocks
DPT6 PUSH IN DESIGN
 6mm² **Page33**
UL 600V / 43A / AWG 20-8
CSA 600V / 43A / AWG 20-8
IEC 1000V / 52A / 0.5-10mm²

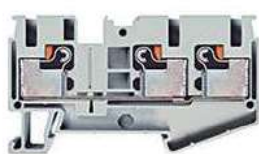

Features of Spring Clamp Terminal Blocks
DPT6/3 PUSH IN DESIGN
 6mm² **Page34**
UL 600V / 43A / AWG 20-8
CSA 600V / 43A / AWG 20-8
IEC 1000V / 52A / 0.5-10mm²



Features of Spring Clamp Terminal Blocks
DPT6/4 PUSH IN DESIGN
 6mm² **Page34**
UL 600V / 43A / AWG 20-8
CSA 600V / 43A / AWG 20-8
IEC 1000V / 52A / 0.5-10mm²



Features of Spring Clamp Terminal Blocks
DPT10 PUSH IN DESIGN
 10mm² **Page34**
UL 600V / 60A / AWG 20-6
CSA 600V / 60A / AWG 20-6
IEC 1000V / 70A / 0.5-16mm²



Features of Spring Clamp Terminal Blocks
DPT10/3 PUSH IN DESIGN
 10mm² **Page35**
UL 600V / 60A / AWG 20-6
CSA 600V / 60A / AWG 20-6
IEC 1000V / 70A / 0.5-16mm²



Features of Spring Clamp Terminal Blocks
DPTN16 PUSH IN DESIGN
 16mm² **Page35**
UL 600V / 85A / AWG 20-4
CSA 600V / 85A / AWG 20-4
IEC 1000V / 90A / 0.5-25mm²



Features of Spring Clamp Terminal Blocks
DPTN16/3 PUSH IN DESIGN
 16mm² **Page35**
UL 600V / 85A / AWG 20-4
CSA 600V / 85A / AWG 20-4
IEC 1000V / 90A / 0.5-25mm²



Features of Spring Clamp Terminal Blocks
DPTN35 PUSH IN DESIGN
 35mm² **Page36**
UL 600V / 115A / AWG 14-2
CSA 600V / 115A / AWG 14-2
IEC 1000V / 125A / 2.5-35mm²

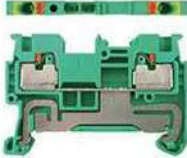

Features of Spring Clamp Ground Terminal Blocks
DPT1.5-PE PUSH IN DESIGN
 1.5mm² **Page37**
UL AWG 26-14
CSA AWG 26-14
IEC 0.14-1.5mm²

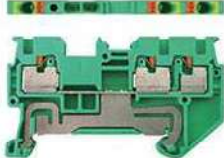

Features of Spring Clamp Ground Terminal Blocks
DPT1.5/3-PE PUSH IN DESIGN
 1.5mm² **Page38**
UL AWG 26-14
CSA AWG 26-14
IEC 0.14-1.5mm²



Features of Spring Clamp Ground Terminal Blocks
DPT1.5/4-PE PUSH IN DESIGN
 1.5mm² **Page38**
UL AWG 26-14
CSA AWG 26-14
IEC 0.14-1.5mm²



Features of Spring Clamp Ground Terminal Blocks
DPT2.5-PE PUSH IN DESIGN
 2.5mm² **Page38**
UL AWG 26-12
CSA AWG 26-12
IEC 0.14-4mm²



Features of Spring Clamp Ground Terminal Blocks
DPT2.5/3-PE PUSH IN DESIGN
 2.5mm² **Page39**
UL AWG 26-12
CSA AWG 26-12
IEC 0.14-4mm²

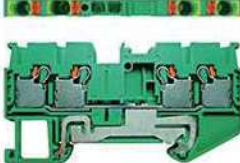

Features of Spring Clamp Ground Terminal Blocks
DPT2.5/4-PE PUSH IN DESIGN
 2.5mm² **Page39**
UL AWG 26-12
CSA AWG 26-12
IEC 0.14-4mm²

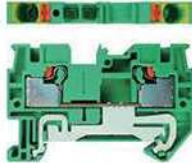

Features of Spring Clamp Ground Terminal Blocks
DPT4-PE PUSH IN DESIGN
 4mm² **Page39**
UL AWG 24-10
CSA AWG 24-10
IEC 0.2-6mm²

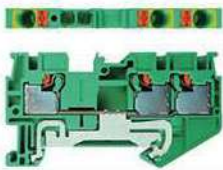

Features of Spring Clamp Ground Terminal Blocks
DPT4/3-PE PUSH IN DESIGN
 4mm² **Page40**
UL AWG 24-10
CSA AWG 24-10
IEC 0.2-6mm²

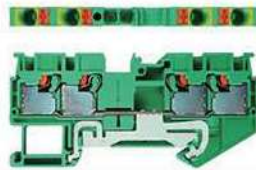

Features of Spring Clamp Ground Terminal Blocks
DPT4/4-PE PUSH IN DESIGN
 4mm² **Page40**
UL AWG 24-10
CSA AWG 24-10
IEC 0.2-6mm²

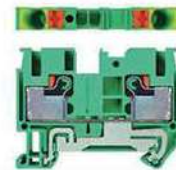

Features of Spring Clamp Ground Terminal Blocks
DPT6-PE PUSH IN DESIGN
 6mm² **Page40**
UL AWG 20-8
CSA AWG 20-8
IEC 0.5-10mm²

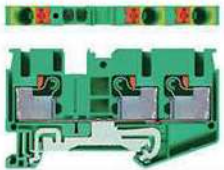

Features of Spring Clamp Ground Terminal Blocks
DPT6/3-PE PUSH IN DESIGN
 6mm² **Page41**
UL AWG 20-8
CSA AWG 20-8
IEC 0.5-10mm²

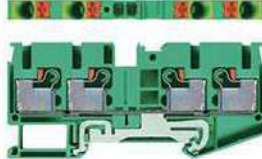

Features of Spring Clamp Ground Terminal Blocks
DPT6/4-PE PUSH IN DESIGN
 6mm² **Page41**
UL AWG 20-8
CSA AWG 20-8
IEC 0.5-10mm²



Features of Spring Clamp Ground Terminal Blocks
DPT10-PE PUSH IN DESIGN
 10mm² **Page41**
UL AWG 20-6
CSA AWG 20-6
IEC 0.5-16mm²

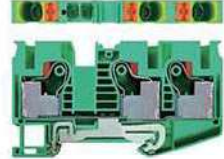

Features of Spring Clamp Ground Terminal Blocks
DPT10/3-PE PUSH IN DESIGN
 10mm² **Page42**
UL AWG 20-6
CSA AWG 20-6
IEC 0.5-16mm²



Features of Spring Clamp Ground Terminal Blocks
DPTN16-PE PUSH IN DESIGN
 16mm² **Page42**
UL AWG 20-4
CSA AWG 20-4
IEC 0.5-25mm²

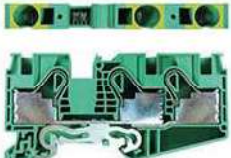

Features of Spring Clamp Ground Terminal Blocks
DPTN16/3-PE PUSH IN DESIGN
 16mm² **Page42**
UL AWG 20-4
CSA AWG 20-4
IEC 0.5-25mm²



Features of Spring Clamp Ground Terminal Blocks
DPTN35-PE PUSH IN DESIGN
 35mm² **Page43**
UL AWG 14-2
CSA AWG 14-2
IEC 2.5-35mm²



COMBI Push In Type Plug In Connection
DSPB2.5/XP PUSH IN DESIGN
 2.5mm² **Page44**
UL 600V / 20A / AWG 28-12
CSA 600V / 20A / AWG 28-12
IEC 500V / 24A / 0.08-2.5mm²



Accessories
End Plate **Page45**



Accessories

For 1.5mm² Marking Tags

Page46



Accessories

For 1.5mm² Marking Tags

Page46



Accessories

For 2.5mm² Marking Tags

Page46



Accessories

For 4mm² Marking Tags

Page46



Accessories

For 6mm² Marking Tags

Page46



Accessories

For 10mm² Marking Tags

Page46



Accessories

For 16mm² Marking Tags

Page46



Accessories

For 35mm² Marking Tags

Page46



Accessories

For 1.5mm² Comb Link

Page47



Accessories

For 1.5mm² Comb Link

Page47



Accessories

For 2.5mm² Comb Link

Page47



Accessories

For 4mm² Comb Link

Page47



Accessories

For 6mm² Comb Link

Page47



Accessories

For 10mm² Comb Link

Page47



Accessories

For 16mm² Comb Link

Page47



Accessories

For 35mm² Comb Link

Page47



Accessories

Strain relief / Snap-lock Fitting

Page47



Orbit Cuts off Utensil

Orbit Cuts off Utensil

Page48

Features of Spring Clamp Terminal Blocks 弹片压接型接线座

Features of Spring Clamp Terminal Blocks

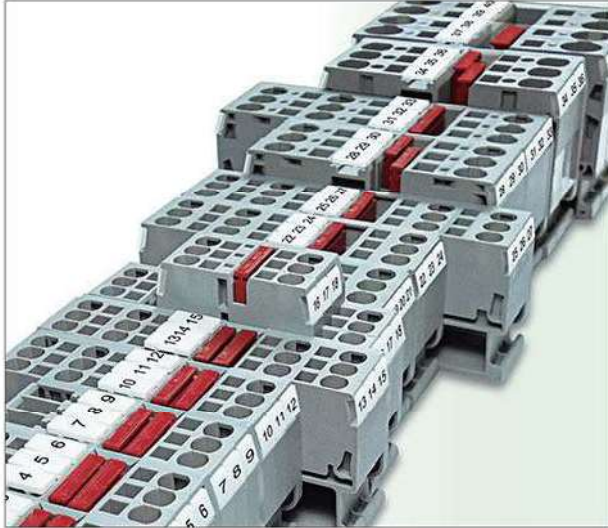

Features of Spring Clamp Terminal Blocks

- Space-saving design / Front connection.
- Vibration proof anti-loosening wire connection with pre-stressed Spring Clamp.
- Easy to operate, fast wiring installation with top wire entry.
- Easy mounting and dismantling from the terminal rail.
- Corrosion-proof terminal points.
- Low contact resistance.
- Easy for the extension of terminal connection.
- Easy handling and safe connection.

弹片压接型接线座之特性

- 节省空间之特性 / 前缘导线连接方式
- 高强度压力的弹度迫紧连接方式，具有抗震与防松的效果
- 操作简便且快速的导线安装方式（顶部进线）
- 抗腐蚀性佳（使用良好的金属材料）
- 接线座从轨道上安装及拆卸
- 容易低接触电阻
- 容易扩充及延伸性佳
- 操作简便且连接处安全性高

DST 1.5-D

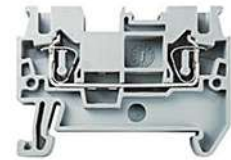

CE 



Specifications (产品规格)	1.5mm ²	
Technical Data (技术参数)	Rated voltage / Rated current / Wire Size	
UL	600V / 15A / AWG 28-14	
CSA	600V / 15A / AWG 28-14	
IEC	500V / 17.5A / 0.08-1.5mm ²	
Insulating Impulse voltage withstand / Pollution degree (额定冲击电压 / 污染等级)	6KV / 3	
Insulation stripping length (mm) (剥线长度)	10mm	
Material / Available Color (材质颜色)	● ● ● ● ●	
Rail Dimensions (导轨尺寸)	T / W / H (mm)	
For TS35x 7.5 	4.2 x 48.8 x 36.5	
For TS35x 15 	4.2 x 48.8 x 44	
Accessories (附件)	Cat. No.	Qty.
End Bracket (终端挡板) 	SEW35	50
End Plate (挡板) 	DD-ST2.5-D	50
Comb Link (边接式联接件) 	ODFBS2-4	50
	ODFBS3-4	50
	ODFBS4-4	50
	ODFBS5-4	50
	ODFBS10-4	10
Marking Tags (标记号) 	DUC-TMF4	10 (侧面 120 位)
	DUC-TM4	10 (正面 120 位)
Tool (工具) 	DS2 (0.4 x 2.5mm)	

Features of Spring Clamp Terminal Blocks 弹片压接型接线座

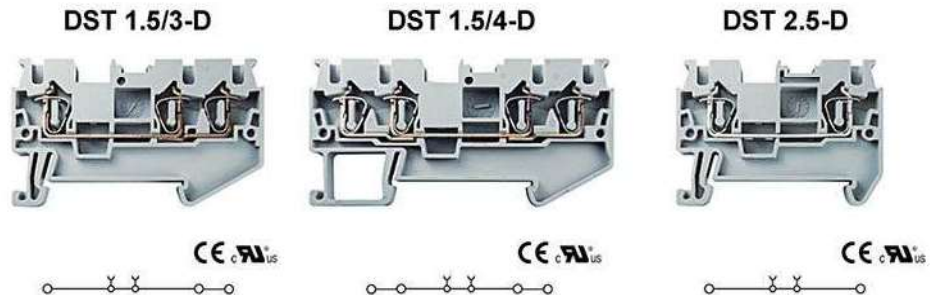

Specifications (产品规格)	1.5mm ²	1.5mm ²	2.5mm ²
Technical Data (技术参数)	Rated voltage / Rated current / Wire Size	Rated voltage / Rated current / Wire Size	Rated voltage / Rated current / Wire Size
UL	600V / 15A / AWG 28-14	600V / 15A / AWG 28-14	600V / 20A / AWG 28-12
CSA	600V / 15A / AWG 28-14	600V / 15A / AWG 28-14	600V / 20A / AWG 28-12
IEC	500V / 17.5A / 0.08-1.5mm ²	500V / 17.5A / 0.08-1.5mm ²	800V / 31A / 0.08-2.5mm ²
Insulating Impulse voltage withstand / Pollution degree (额定冲击电压 / 污染等级)	6KV / 3	6KV / 3	8KV / 3
Insulation stripping length (mm) (剥线长度)	10mm	10mm	10mm
Material / Available Color (材质颜色)			
Rail Dimensions (导轨尺寸)	T / W / H (mm)	T / W / H (mm)	T / W / H (mm)
For TS35x 7.5	4.2 x 60.7 x 36.5	4.2 x 72.6 x 36.5	5.2 x 48.8 x 36.5
For TS35x 15	4.2 x 60.7 x 44	4.2 x 72.6x 44	5.2 x 48.8 x 44
Accessories (附件)	Cat. No. Qty.	Cat. No. Qty.	Cat. No. Qty.
End Bracket (终端挡板)	SEW35 50	SEW35 50	SEW35 50
End Plate (挡板)	DD-ST2.5/3-D 50	DD-ST2.5/4-D 50	DD-ST2.5-D 50
Comb Link (边接式联接件)	ODFBS2-4 50 ODFBS3-4 50 ODFBS4-4 50 ODFBS5-4 50 ODFBS10-4 10	ODFBS2-4 50 ODFBS3-4 50 ODFBS4-4 50 ODFBS5-4 50 ODFBS10-4 10	ODFBS2-5 50 ODFBS3-5 50 ODFBS4-5 50 ODFBS5-5 50 ODFBS10-5 10
Marking Tags (标记号)	DUC-TMF4 10 (侧面 120 位) DUC-TM4 10 (正面 120 位)	DUC-TMF4 10 (侧面 120 位) DUC-TM4 10 (正面 120 位)	DUC-TMF5 96 (侧面 96 位) DUC-TM5 96 (正面 69 位)
Tool (工具)	DS2 (0.4 x 2.5mm)	DS2(0.4 x 2.5mm)	DS3(0.4 x 3.5mm)

Features of Spring Clamp Terminal Blocks 弹片压接型接线座

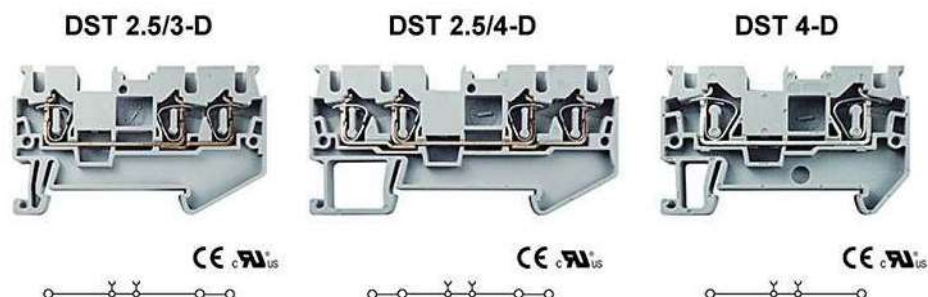

Specifications (产品规格)	2.5mm ²	2.5mm ²	4mm ²
Technical Data (技术参数)	Rated voltage / Rated current / Wire Size	Rated voltage / Rated current / Wire Size	Rated voltage / Rated current / Wire Size
UL	600V / 20A / AWG 28-12	600V / 20A / AWG 28-12	600V / 30A / AWG 28-10
CSA	600V / 20A / AWG 28-12	600V / 20A / AWG 28-12	600V / 30A / AWG 28-10
IEC	800V / 28A / 0.08-2.5mm ²	800V / 28A / 0.08-2.5mm ²	800V / 40A / 0.08-4mm ²
Insulating Impulse voltage withstand / Pollution degree (额定冲击电压 / 污染等级)	8KV / 3	8KV / 3	8KV / 3
Insulation stripping length (mm) (剥线长度)	10mm	10mm	10mm
Material / Available Color (材质颜色)			
Rail Dimensions (导轨尺寸)	T / W / H (mm)	T / W / H (mm)	T / W / H (mm)
For TS35x 7.5	5.2 x 60.7 x 36.5	5.2 x 72.4 x 36.5	6.2 x 56.1 x 36.5
For TS35x 15	5.2 x 60.7 x 44	5.2 x 72.4 x 44	6.2 x 56.1 x 44
Accessories (附件)	Cat. No. Qty.	Cat. No. Qty.	Cat. No. Qty.
End Bracket (终端挡板)	SEW35 50	SEW35 50	SEW35 50
End Plate (挡板)	DD-ST2.5/3-D 50	DD-ST2.5/4-D 50	DD-ST4-D 50
Comb Link (边接式联接件)	ODFBS2-5 50 ODFBS3-5 50 ODFBS4-5 50 ODFBS5-5 50 ODFBS10-5 10	ODFBS2-5 50 ODFBS3-5 50 ODFBS4-5 50 ODFBS5-5 50 ODFBS10-5 10	ODFBS2-6 50 ODFBS3-6 50 ODFBS4-6 50 ODFBS5-6 50 ODFBS10-6 10
Marking Tags (标记号)	DUC-TMF5 10 (侧面96位) DUC-TM5 10 (正面96位)	DUC-TMF5 10 (侧面96位) DUC-TM5 10 (正面96位)	DUC-TMF6 10 (侧面80位) DUC-TM6 10 (正面80位)
Tool (工具)	DS3 (0.4 x 3.5mm)	DS3 (0.4 x 3.5mm)	DS3 (0.4 x 4.0mm)

Features of Spring Clamp Terminal Blocks 弹片压接型接线座

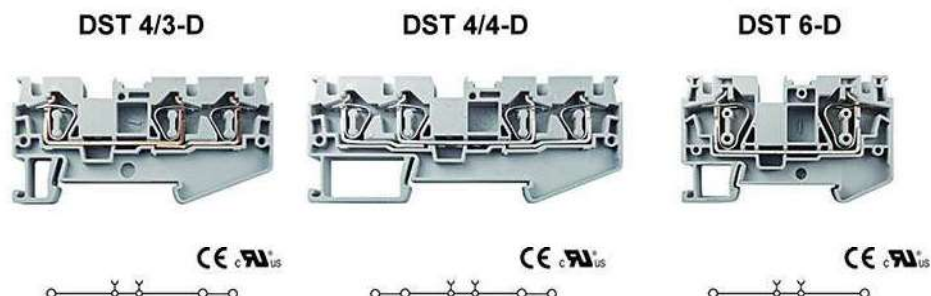

Specifications (产品规格)	4mm ²	4mm ²	6mm ²
Technical Data (技术参数)	Rated voltage / Rated current / Wire Size	Rated voltage / Rated current / Wire Size	Rated voltage / Rated current / Wire Size
UL	600V / 30A / AWG 28-10	600V / 30A / AWG 28-10	600V / 48A / AWG 24-8
CSA	600V / 30A / AWG 28-10	600V / 30A / AWG 28-10	600V / 48A / AWG 24-8
IEC	800V / 40A / 0.08-4mm ²	800V / 40A / 0.08-4mm ²	1000V / 52A / 0.2-6mm ²
Insulating Impulse voltage withstand / Pollution degree (额定冲击电压/污染等级)	8KV / 3	8KV / 3	8KV / 3
Insulation stripping length (mm) (剥线长度)	10mm	10mm	12mm
Material / Available Color (材质颜色)			
Rail Dimensions (导轨尺寸)	T / W / H (mm)	T / W / H (mm)	T / W / H (mm)
For TS35x 7.5	6.2 x 71.7 x 36.5	6.2 x 87.3 x 36.5	8.2 x 69.5 x 43.5
For TS35x 15	6.2 x 71.7 x 44	6.2 x 87.3 x 44	8.2 x 69.5 x 51
Accessories (附件)	Cat. No. Qty.	Cat. No. Qty.	Cat. No. Qty.
End Bracket (终端挡板)	SEW35 50	SEW35 50	SEW35 50
End Plate (挡板)	DD-ST4/3-D 50	DD-ST4/4-D 50	DD-ST6-D 50
Comb Link (边接式联接件)	ODFBS2-6 50 ODFBS3-6 50 ODFBS4-6 50 ODFBS5-6 50 ODFBS10-6 10	ODFBS2-6 50 ODFBS3-6 50 ODFBS4-6 50 ODFBS5-6 50 ODFBS10-6 10	ODFBS2-8 50 ODFBS3-8 50 ODFBS4-8 50 ODFBS5-8 50 ODFBS10-8 10
Marking Tags (标记号)	DUC-TMF6 10 (侧面80位) DUC-TM6 10 (正面80位)	DUC-TMF6 10 (侧面80位) DUC-TM6 10 (正面80位)	DUC-TMF8 10 (侧面56位) DUC-TM8 10 (正面56位)
Tool (工具)	DS3 (0.4 x 4.0mm)	DS3 (0.4 x 4.0mm)	DS4 (0.4 x 5.5mm)

Features of Spring Clamp Terminal Blocks 弹片压接型接线座



Specifications (产品规格)	6mm ²	10mm ²	10mm ²
Technical Data (技术参数)	Rated voltage / Rated current / Wire Size	Rated voltage / Rated current / Wire Size	Rated voltage / Rated current / Wire Size
UL	600V / 48A / AWG 24-8	600V / 65A / AWG 24-6	600V / 60A / AWG 24-6
CSA	600V / 48A / AWG 24-8	600V / 65A / AWG 24-6	600V / 60A / AWG 24-6
IEC	800V / 52A / 0.2-6mm ²	1000V / 65A / 0.2-10mm ²	1000V / 65A / 0.2-10mm ²
Insulating Impulse voltage withstand / Pollution degree (额定冲击电压 / 污染等级)	8KV / 3	8KV / 3	8KV / 3
Insulation stripping length (mm) (剥线长度)	12mm	18mm	18mm
Material / Available Color (材质颜色)			
Rail Dimensions (导轨尺寸)	T / W / H (mm)	T / W / H (mm)	T / W / H (mm)
For TS35x 7.5	8.2 x 90.5 x 43.5	10.2 x 71.3 x 50.5	10.2 x 95.3 x 50.5
For TS35x 15	8.2 x 90.5 x 51	10.2 x 71.3x 58	10.2 x 95.3 x 58
Accessories (附件)	Cat. No. Qty.	Cat. No. Qty.	Cat. No. Qty.
End Bracket (终端挡板)	SEW35 50	SEW35 50	SEW35 50
End Plate (挡板)	DD-ST6/3-D 50	DD-ST10-D 50	DD-ST10/3-D 50
Comb Link (边接式联接件)	ODFBS2-8 50 ODFBS3-8 50 ODFBS4-8 50 ODFBS5-8 50 ODFBS10-8 10	ODFBS2-10 10 ODFBS5-10 10	ODFBS2-10 10 ODFBS5-10 10
Marking Tags (标记号)	DUC-TMF8 10 (侧面 56位) DUC-TM8 10 (正面 56位)	DUC-TMF10 10 (侧面 48位) DUC-TM10 10 (正面 48位)	DUC-TMF10 10 (侧面 48位) DUC-TM10 10 (正面 48位)
Tool (工具)	DS4 (0.4 x 5.5mm)	DS5 (0.4 x 6.5mm)	DS5 (0.4 x 6.5mm)

登录后查看

完整版

目录书