

NOTE:

1.MATERIAL:

- 1.1 INSULATOR:LCP E130I UL94V-0;BLACK
- 1.2 CONTACT:C2680-H(T=0.20mm)
- 1.3 PEG:C2680-H(T=0.20mm)

2.ELECTRICAL CHARACTERISTICS:

- 2.1 CONTACT RESISTANCE:40mΩ Max
- 2.2 CONTACT CURRENT RATING:2A
- 2.3 DIELECTRIC WITHSTANDING VOLTAGE:500 V
- 2.4 INSULATION RESISTANCE: 100 MEGOHMS Min
- 2.5 OPERATING TEMPERATURE:-25°C ~ 85°C

3 MECHANICAL CHARACTERISTICS:

- 3.1 MATING FORCE: 2.5Kgf Max
- 3.2 UNMATED FORCE: 1ST 0.4kgf Min/3rd 0.15kgf/30th 0.12kgf Min;
- 3.3 DURABILITY:30 CYCLES

GENERAL TOLERANCES

- 0.0±0.25
- 0.00±0.20
- 0.000±0.08



CKT	DIM A	DIM B	DIM C	DIM D
2	1.20	1.20	2.65	4.20
5	1.20	4.80	6.25	7.80

ITEM	PARTS	QTY	MATERIAL	REMARK
3	PEG	2	C2680	80u"Min Sn PLATING OVER ALL, 50u"Min Ni UNDER PLATING OVER ALL.
2	CONTACT	5	C2680	GF ON THE CONTACT AREA, MATTE TIN ON THE SOLDER AREA, 50u"Min Ni UNDER PLATING OVER ALL.
1	HOUSING	1	LCP E130I	UL94V-0, BLACK

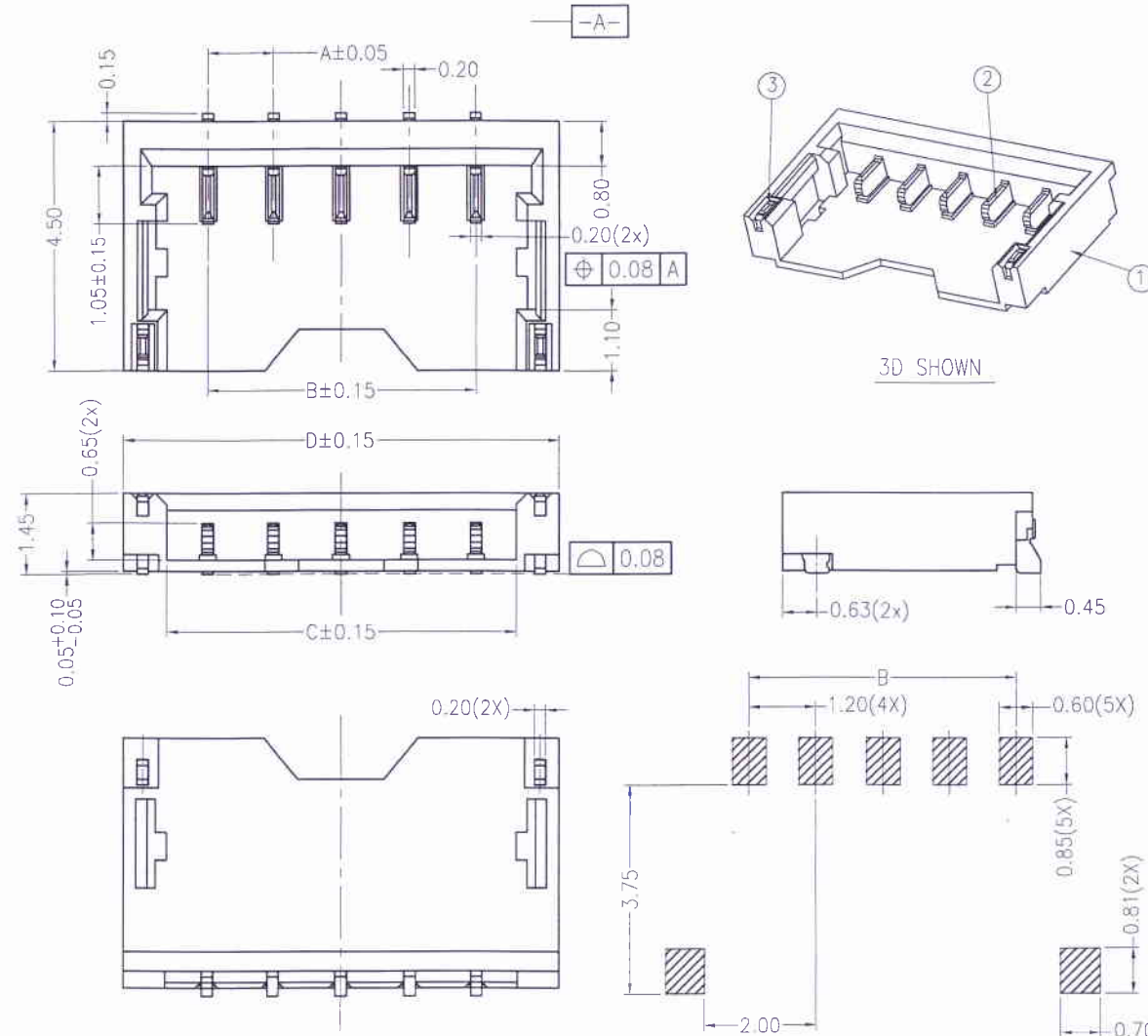

3D SHOWN

RECOMMENDED PCB LAYOUT
GENERAL TOLERANCE ±0.05

The product using material and processing must conform to the "WI-PZ-142" HSF technical standard control requirements

REV.	REVISION RECORD	DATE	SCALE:	NAME	DATE	PART. NO:	DWG. NO:	JCTC® TERMINAL&CONNECTORS
A0	新图面发行	2020.08.03	1:1	SP	20.08.03	11202W90-NP-S-W1	ENDE05	
			APPROVED	王	20.08.03			
			DESIGNER	王	20.08.03	TITLE:		
			DRAWN	王	20.08.03	1.2PH Wafer H1.45		

REV: A0 SHEET: 1/2

PART 1: 包装方向

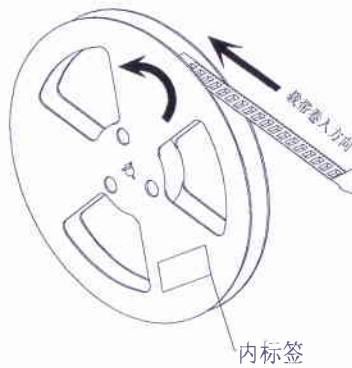

PART 2: 卷盘规格

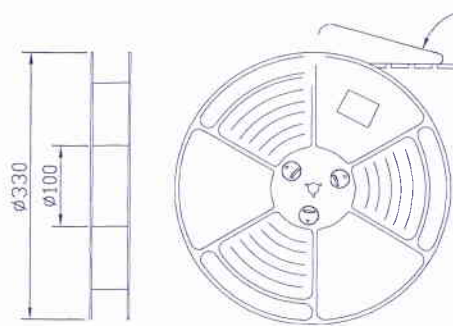

3000pcs/REEL

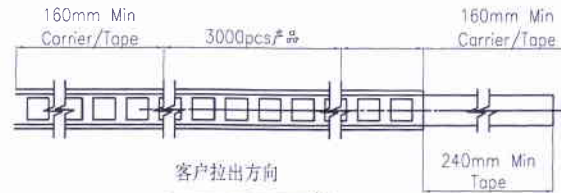
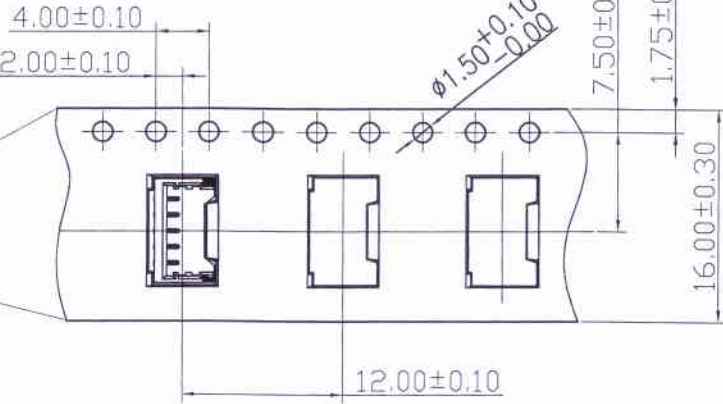

- 说明
1. 10个孔位之间的累计公差 $\pm 0.2\text{mm}$
 2. 载带扇形公差 $250\text{mm} \pm 0.1\text{mm}$
 3. 材质: 防静电聚苯乙烯。
 4. 包装数量: 3000PCS/盘, 19盘/57000PCS/箱。
 5. 包装料盘外径13寸。
 6. 包装好的产品, 注意轻拿轻放, 防止搬用过程中导致产品变形。

PART 3: 装箱

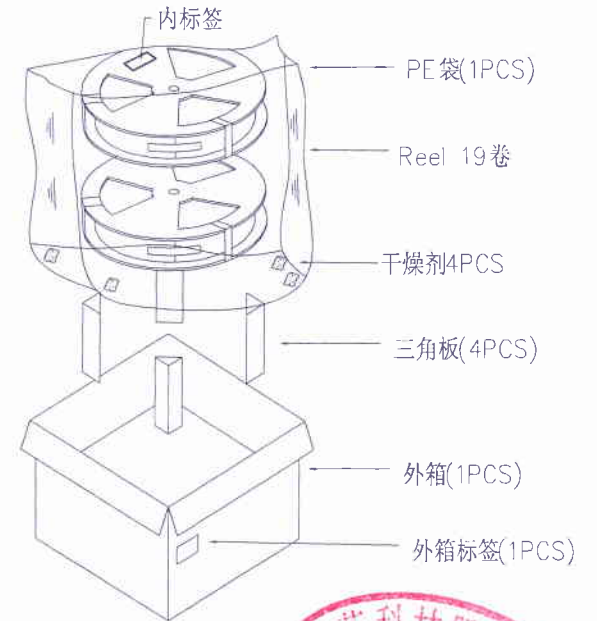

外箱标签
(依客户要求
填写、张贴)



REV.	REVISION RECORD	DATE	GENERAL TOLERANCES		SCALE:	NAME	DATE	PART. NO:	DWG. NO:	JCTC® TERMINAL&CONNECTORS
A0	新图面发行	2020.08.03	LINEAR	ANGLES	1:1			11202W90-NP-S-W1	ENDE05	
			0.0 \pm 0.25	X° REF \pm 6°	APPROVED	[Signature]	20.08.03	TITLE:		
			0.00 \pm 0.15	X° \pm 3°	DESIGNER	[Signature]	20.08.03	1.2PII Wafer H1.45		
			0.000 \pm 0.08	X° X' \pm 2°	DRAWN	[Signature]	20.08.03	REV: A0	SHEET: 2/2	