

**SPECIFICATIONS**  
 Current Rating: 1A AC,DC  
 Voltage Rating: 125V AC,DC  
 Temperature Range: -25°C ~ +85°C  
 Contact Resistance: 20mΩ Max.  
 Insulation Resistance: 100MΩ Min.  
 Withstanding Voltage: 500V AC/minute  
 Contact: Phosphor Bronze/Matte Tin-plated  
 Solder Tabs: Brass/Matte Tin-plated  
 Insulator: Thermal Plasticity Resin, UL 94V-0  
 Halogen Free  
 Color: Natural(Beige)



Circuits	Dimensions	
	A	B
2P	7.65	7.65
3P	8.90	8.90
4P	10.15	10.15
5P	11.40	11.40
6P	12.65	12.65
7P	13.90	13.90
8P	15.15	15.15
9P	16.40	16.40
10P	17.65	17.65
11P	18.90	18.90
12P	20.15	20.15
14P	22.65	22.65
15P	23.90	23.90
16P	25.15	25.15
20P	30.15	30.15
30P	42.65	42.65



11255W90-NP-S-HF-R  
 ① ② ③ ④ ⑤ ⑥

- ① Series No.
- ② W00 : Up Contact
- ③ No. of Circuits
- ④ S : SMT Type
- ⑤ HF : Halogen Free
- ⑥ R : Reel pack

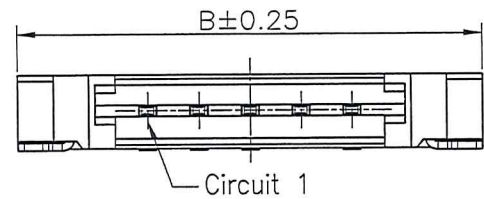
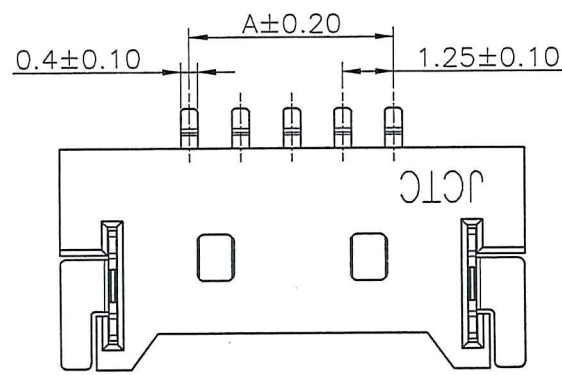
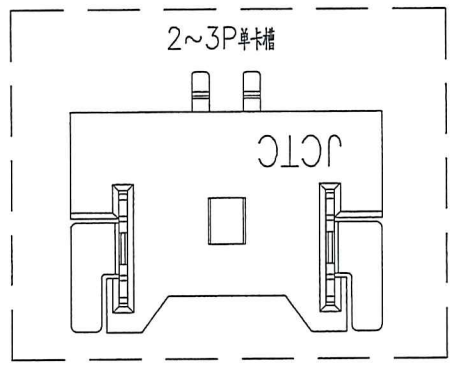
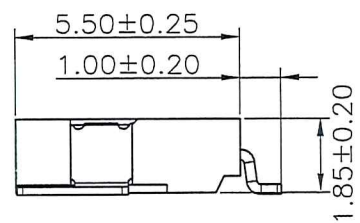
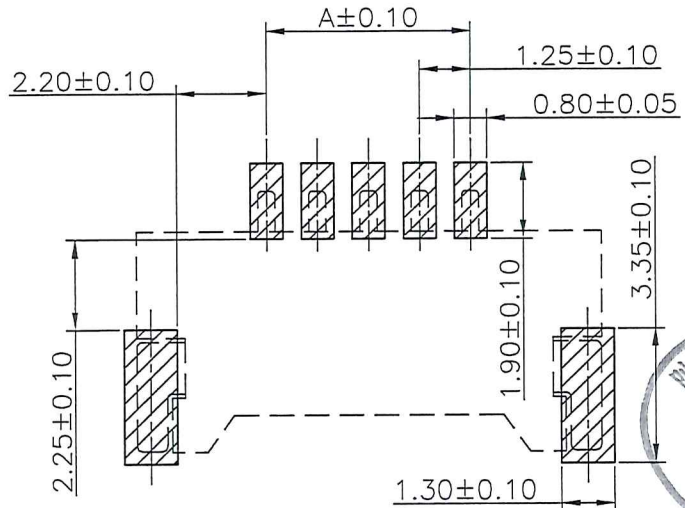

REV.	REVISION RECORD	DATE	GENERAL TOLERANCES		SCALE	NAME	DATE	PART NO.	DWG NO.	 <b>TERMINAL&amp;CONNECTORS</b>			
			LINEAR	ANGLES	1:1								
A0	新图面发行	16.04.27	0.0±0.25	X° REF±6°	APPROVED	Nelson	22.12.05	11255W90-NP-S-HF	ENDE05	REV	A2	SHEET	1/2
A1	变更公司名称	17.03.30	0.00±0.15	X° ±3°	DESIGNER	ML	22.12.05	TITLE					
A2	ECN20221116274	22.11.30	0.000±0.08	X° X' ±2°	DRAWN	Fau	22.11.30	1.25mm PITCH 90° SMT TYPE WAFER					

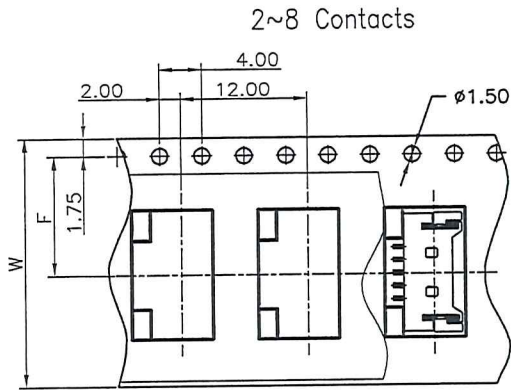

Unreeing direction →

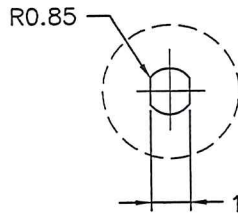
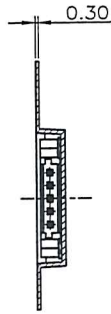

9~30 Contacts

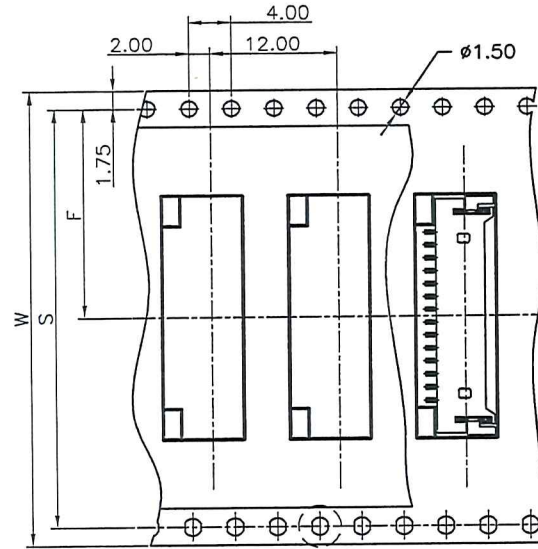

Unreeing direction →

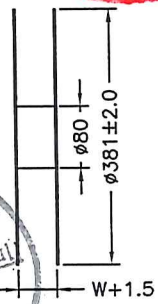
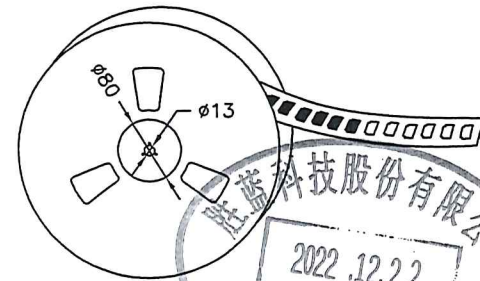
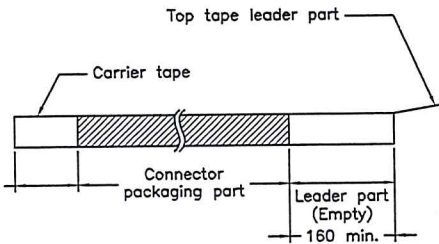

Number of Contacts	W±0.3	F±0.1	S±0.1	Pcs/Reel	Pcs/Box
2P	16	7.50	--	2,000	30,000
3~8P	24	11.50	--	2,000	20,000
9~12P	32	14.20	28.40	2,000	16,000
13~20P	44	20.20	40.40	2,000	12,000
30P	56	26.20	52.40	2,000	10,000

REV.	REVISION RECORD	DATE	GENERAL TOLERANCES		SCALE	NAME	DATE	PART NO.	DWG NO.	
A0	新图面发行	16.04.27		LINEAR	1:1		22.12.05	11255W90-NP-S-HF	ENDE05	
A1	变更公司名称	17.03.30		ANGLES	APPROVED					
A2	ECN20221116274	22.11.30	UNIT: MM	0.0±0.15	X° REF±6°	DESIGNER	22.12.05	TITLE	1.25mm PITCH 90° SMT TYPE WAFER	
			SIZE: A4	0.000±0.08	X° X'±2°	DRAWN	Fau	22.11.30		

REV	A2	SHEET	2/2
-----	----	-------	-----