

Circuits Part No	Dimensions		
	A	B	C
2P	--	8.00	0.78
3P	4.00	10.00	1.20
4P	6.00	12.00	1.50
5P	8.00	14.00	1.50
6P	10.00	16.00	1.50
7P	12.00	18.00	1.50
8P	14.00	20.00	1.50
9P	16.00	22.00	1.50
10P	18.00	24.00	7.60
11P	20.00	26.00	7.60
12P	22.00	28.00	7.60

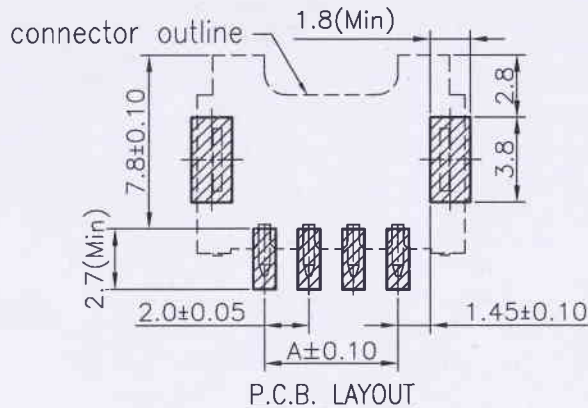

Specifications:
 Rated Voltage : 250V AC/DC
 Rated Current : 3A AC,DC
 Withstand Voltage : 800V AC/minute
 Contact Resistance : 10mΩ(MAX.)
 Insulation Resistance : 1000MΩ(MIN.)
 Temperature Range : -25°C~+85°C
 The product using material and processing must conform to the "WI-PZ-142" HSF technical standard/control requirements

12002W90-NPX-SA-XX-NK-R

- ① Series No.
- ② W90 : Side Contact
W00 : Up Contact
- ③ No. of Circuits
- ④ X : Product color(A--Y)
Blank : Natural type
- ⑤ S : SMT TYPE
- ⑥ A : A TYPE
- ⑦ XX : Halogen Free
- ⑧ NK : No Mark
Blank : Mark
- ⑨ R : Tape & Reel



No.	Description	Material	Color
a	Insulator	Nylon 6T,UL94V-0	Natural(Beige)
		LCP,UL94V-0	Natural(Black)
b	PIN	Brass/Tin-plated	--
c	Solder Tabs	Brass/Tin-plated	--

REV.	REVISION RECORD	DATE	GENERAL TOLERANCES	SCALE:	NAME	DATE	JCTC® 胜蓝科技股份有限公司 TERMINAL&CONNECTORS 东莞市富智达电子科技有限公司	PART NO:
C0	新图面发行	13.04.24	LINEAR	1:1				
C1	WN1312270229	13.12.27	0.0±0.25	ANGLES	APPROVED			DWG NO:
C2	更新公司名称	18.11.15	X° REF±6°	0.00±0.15	DESIGNER	伍文聪 18.11.20		ENDE05
			X° ±3°	0.000±0.08	DRAWN	伍文聪	18.11.15	TITLE: PA 2.00mm PITCH 90° SMT WAFER
			X° X'±2°					REV: C2 SHEET: 1/2



2~5 Contacts

6~12 Contacts

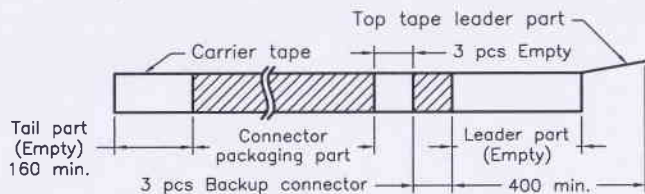
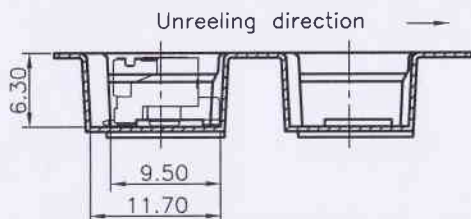
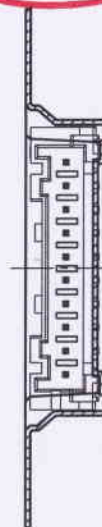
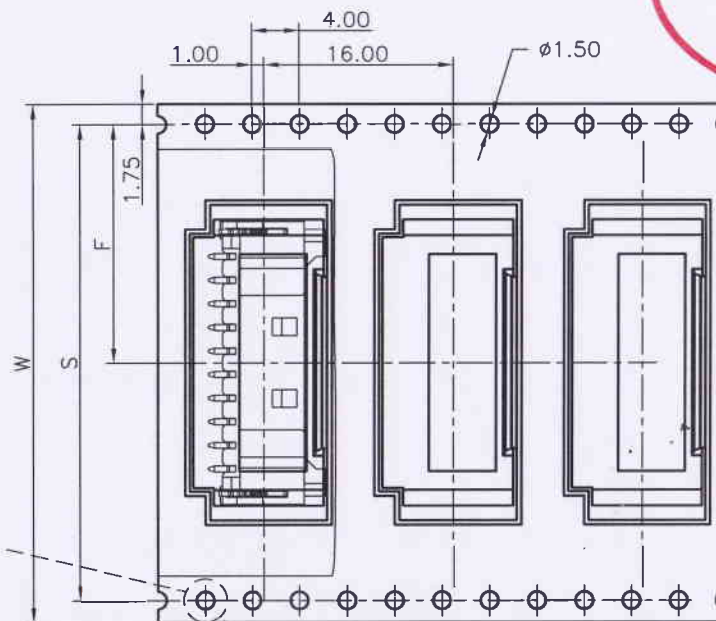
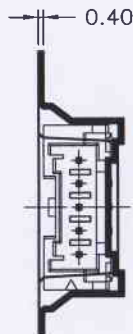
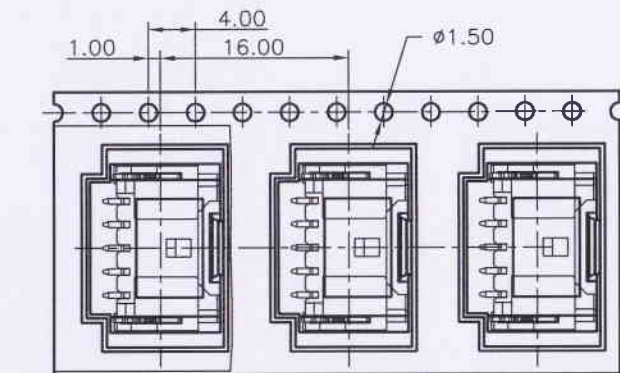

Unreeling direction →

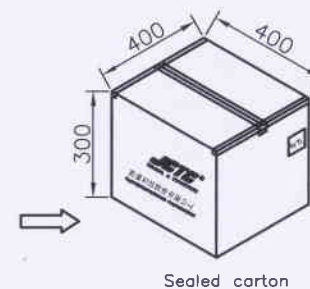
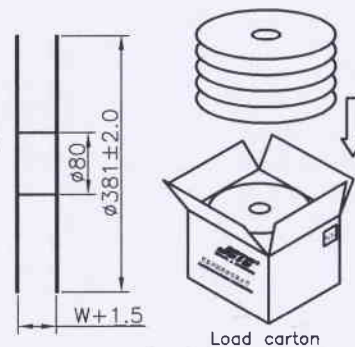
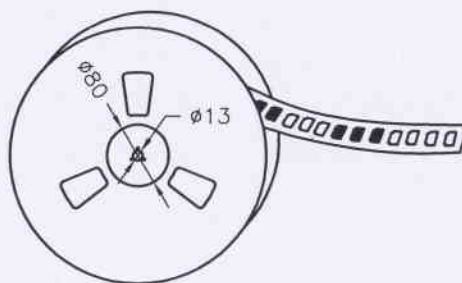

Number of Contacts	W±0.3	F±0.1	S±0.1	Pcs/Reel	Pcs/Box
2~5P	24	11.50		800	8000
6P, 7P	32	14.20	28.40	800	6400
8~12P	44	20.20	40.40	800	4800

REV.	REVISION RECORD		DATE	GENERAL TOLERANCES		SCALE:	NAME	DATE	PART. NO: 12002W90-NPX-SA-NK
C0	新图面发行		13. 04. 24	LINEAR	ANGLES	1:1			
C1	WN1312270229		13. 12. 27	0.0±0.25	X° REF±6°	APPROVED	<i>[Signature]</i>		
C2	更新公司名称		18. 11. 15	0.00±0.15	X° ±3°	DESIGNER	伍文聪	18.11.20	
				SIZE: A4	0.000±0.08	DRAWN	伍文聪	18. 11. 15	
TITLE: PA 2.00mm PITCH 90° SMT WAFER								DWG. NO: ENDE05	REV: C2 SHEET: 2/2

1

2

3

4

5

6

7

8